

INSTALLATION INSTRUCTIONS

CH33 Series Units

EVAPORATOR COILS
505,264M (65484510)
01/10
Supersedes 11/09

TP Technical
Publications
Litho U.S.A.

**RETAIN THESE INSTRUCTIONS
FOR FUTURE REFERENCE**

⚠ WARNING

Improper installation, adjustment, alteration, service or maintenance can cause personal injury, loss of life, or damage to property.

Installation and service must be performed by a licensed professional installer (or equivalent) or a service agency.

⚠ WARNING

Risk of explosion or fire.

Can cause injury or death.

Recover all refrigerant to relieve pressure before opening the system.

⚠ CAUTION

Physical contact with metal edges and corners while applying excessive force or rapid motion can result in personal injury. Be aware of, and use caution when working near these areas during installation or while servicing this equipment.

⚠ IMPORTANT

The Clean Air Act of 1990 bans the intentional venting of refrigerant (CFCs, HCFCs and HFCs) as of July 1, 1992. Approved methods of recovery, recycling or reclaiming must be followed. Fines and/or incarceration may be levied for noncompliance.

Table of Contents

General	1
Shipping and Packing List	1
Specifications	2
Dimensions	1
Releasing Air Charge	4
Unit Installation	4
Refrigerant Line Set	6
Connections	6
Refrigerant Metering Device	6
Leak Testing, Evacuating and Charging	8
Sealing Ducts	8
Condensate Drain Connection	8
Blower Speed Connection	10
Maintenance	10

General

CH33 horizontal evaporator coils are designed for use with air conditioner or heat pump units. Each coil is equipped with a compression fitting that provides convenient field installation of a refrigerant metering device. Either a refrigerant metering orifice (factory installed in coils and provided with some OEM air conditioner units) or a thermostatic expansion valve (ordered separately) may be used in air conditioner unit applications. A check expansion valve (ordered separately) is the only metering device approved for use in heat pump applications.

Refer to the CH33 Engineering Handbook for proper use of these coils with specific OEM furnaces, air conditioner units, heat pumps and line sets.

These instructions are intended as a general guide and do not supersede local or national codes in any way. Consult authorities who have jurisdiction before installation.

Shipping and Packing List

Package 1 of 1 contains the following:

1 — CH33 evaporator coil

Check the components for shipping damage. If you find any damage, immediately contact the last carrier.



Specifications								
General Data	Model No.	CH33 -18A-2F	CH33 -19A-2F	CH33 -24/30A-2F	CH33 -25A-2F	CH33 -25B-2F	CH33 -31A-2F	CH33 -31B-2F
		Nominal size - tons	1.5	1.5	2/2.5	2	2	2.5
Line Connections	Suction/Vapor o.d. - in. sweat	3/4	3/4	3/4	3/4	3/4	3/4	3/4
	Liquid o.d. - in. sweat	3/8	3/8	3/8	3/8	3/8	3/8	3/8
	Condensate drain (fpt) - in.	3/4	3/4	3/4	3/4	3/4	3/4	3/4
RFCIV metering device orifice size		See Table 1.						
Evaporator Coil	Net face area - sq. ft.	1.75	3.5	3.5	3.5	3.5	4.33	4.67
	Tube diameter - in.	3/8	3/8	3/8	3/8	3/8	3/8	3/8
	Number of rows	2	2	2	3	2	3	3
	Fins per inch	18	19	18	14	19	16	14
Horizontal Matching Furnace	Cabinet Designation	A	A	A	A	B	A	B
	Coil and Furnace Height	14-1/2	14-1/2	14-1/2	14-1/2	17-1/2	14-1/2	17-1/2
Shipping Data	lbs. - 1 package	20	37	42	38	38	40	45

Specifications							
General Data	Model No.	CH33 -36A-2F	CH33 -36B-2F	CH33 -36C-2F	CH33 -42B-2F	CH33 -43B-2F	CH33 -43C-2F
		Nominal size - tons	3	3	3	3.5	3.5
Line Connections	Suction/Vapor o.d. - in. sweat	3/4	3/4	3/4	7/8	7/8	7/8
	Liquid o.d. - in. sweat	3/8	3/8	3/8	3/8	3/8	3/8
	Condensate drain (fpt) - in.	3/4	3/4	3/4	3/4	3/4	3/4
RFCIV metering device orifice size		See Table 1.					
Evaporator Coil	Net face area - sq. ft.	3.5	4.67	5.83	4.67	5.78	5.83
	Tube diameter - in.	3/8	3/8	3/8	3/8	3/8	3/8
	Number of rows	3	2	2	3	4	3
	Fins per inch	12	18	18	12	12	13
Horizontal Matching Furnace	Cabinet Designation	A	B	C	B	B	C
	Coil and Furnace Height	14-1/2	17-1/2	21	17-1/2	17-1/2	21
Shipping Data	lbs. - 1 package	54	44	48	60	76	82

Specifications							
General Data	Model No.	CH33 -44/48B-2F	CH33 -48C-2F	CH33 -49C-2F	CH33 -50/60C-2F	CH33 -60D-2F	CH33 -62D-2F
		Nominal size - tons	3.5/4	4	4	4/5	5
Line Connections	Suction/Vapor o.d. - in. sweat	7/8	7/8	7/8	7/8	7/8	7/8
	Liquid o.d. - in. sweat	3/8	3/8	3/8	3/8	3/8	3/8
	Condensate drain (fpt) - in.	3/4	3/4	3/4	3/4	3/4	3/4
RFCIV metering device orifice size		See Table 1.					
Evaporator Coil	Net face area - sq. ft.	5.78	5.83	7.22	7.22	6.42	7.94
	Tube diameter - in.	3/8	3/8	3/8	3/8	3/8	3/8
	Number of rows	3	3	3	3	3	3
	Fins per inch	12	12	13	12	12	12
Horizontal Matching Furnace	Cabinet Designation	B	C	C	C	D	D
	Coil and Furnace Height	17-1/2	21	21	21	24-1/2	24-1/2
Shipping Data	lbs. - 1 package	72	76	86	86	87	97

Dimensions - Inches (MM)

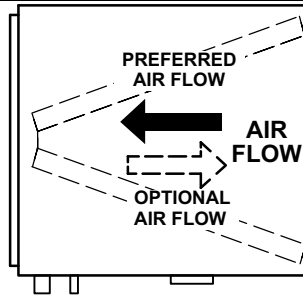

TOP VIEW

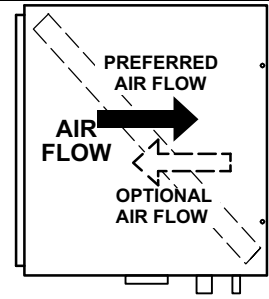

**TOP VIEW
CH33-18A**

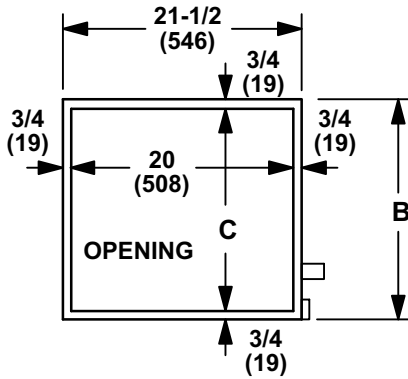

END VIEW

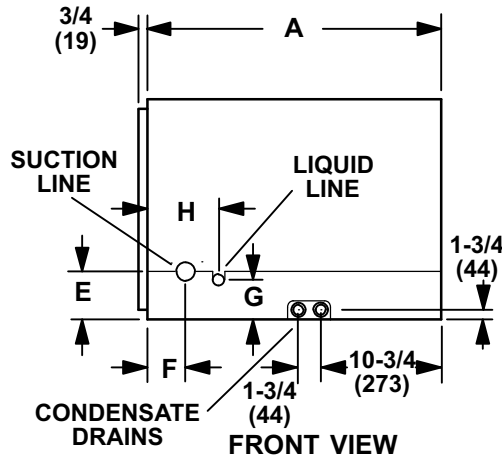

FRONT VIEW

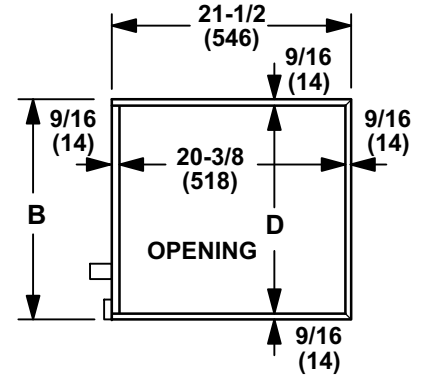

END VIEW

Model No.	A		B		C		D		E		F		G		H	
	in.	mm	in.	mm	in.	mm	in.	mm	in.	mm	in.	mm	in.	mm	in.	mm
CH33-18A-2F	21-1/2	546	14-1/2	368	13	330	13-3/8	340	3-3/4	95	3-1/4	83	2-3/4	70	1-3/4	44
CH33-19A-2F	26-1/2	673	14-1/2	368	13	330	13-3/8	340	4	102	2-1/8	54	3	76	4-7/8	124
CH33-24/30A-2F	26-1/2	673	14-1/2	368	13	330	13-3/8	340	4	102	2-1/8	54	3	76	4-7/8	124
CH33-25A-2F	26-1/2	673	14-1/2	368	13	330	13-3/8	340	4	102	2-1/8	54	3	76	4-7/8	124
CH33-25B-2F	26-1/2	673	17-1/2	444	16	406	16-3/8	416	4	102	2-1/8	54	3	76	4-7/8	124
CH33-31A-2F	31-1/2	800	14-1/2	368	13	330	13-3/8	340	4	102	2-1/8	54	3	76	4-7/8	124
CH33-31B-2F	26-1/2	673	17-1/2	444	16	406	16-3/8	416	4	102	2-1/8	54	3	76	4-7/8	124
CH33-36A-2F	26-1/2	673	14-1/2	368	13	330	13-3/8	340	4	102	2-1/8	54	3	76	4-7/8	124
CH33-36B-2F	26-1/2	673	17-1/2	444	16	406	16-3/8	416	4	102	2-1/8	54	3	76	4-7/8	124
CH33-36C-2F	26-1/2	673	21	533	19-1/2	495	19-7/8	505	4	102	2-1/8	54	3	76	4-7/8	124
CH33-42B-2F	26-1/2	673	17-1/2	444	16	406	16-3/8	416	4	102	2-1/8	54	3	76	4-7/8	124
CH33-43B-2F	31-1/2	800	17-1/2	444	16	406	16-3/8	416	4	102	2-1/8	54	3	76	4-7/8	124
CH33-43C-2F	26-1/2	673	21	533	19-1/2	495	19-7/8	505	4	102	2-1/8	54	3	76	4-7/8	124
CH33-44/48B-2F	31-1/2	800	17-1/2	444	16	406	16-3/8	416	4	102	2-1/8	54	3	76	4-7/8	124
CH33-48C-2F	26-1/2	673	21	533	19-1/2	495	19-7/8	505	4	102	2-1/8	54	3	76	4-7/8	124
CH33-49C-2F	31-1/2	800	21	533	19-1/2	495	19-7/8	505	4	102	2-1/8	54	3	76	4-7/8	124
CH33-50/60C-2F	31-1/2	800	21	533	19-1/2	495	19-7/8	505	4	102	2-1/8	54	3	76	4-7/8	124
CH33-60D-2F	26-1/2	673	24-1/2	622	23	584	23-3/8	594	4	102	2-1/8	54	3	76	4-7/8	124
CH33-62D-2F	31-1/2	800	24-1/2	622	23	584	23-3/8	594	4	102	2-1/8	54	3	76	4-7/8	124

Table 1. Orifice Size Shipped with CH33

Model Number.	Orifice Size
CH33-18A-2F	0.051
CH33-19A-2F	0.051
CH33-24/30A-2F	0.057
CH33-25A-2F	0.057
CH33-25B-2F	0.057
CH33-31A-2F	0.065
CH33-31B-2F	0.065
CH33-36A-2F	0.073
CH33-36B-2F	0.073
CH33-36C-2F	0.073
CH33-42B-2F	0.076
CH33-43B-2F	0.076
CH33-43C-2F	0.076
CH33-44/48-2F	0.076
CH33-48C-2F	0.082
CH33-49C-2F	0.082
CH33-50/60C-2F	0.082
CH33-60D-2F	0.093
CH33-62D-2F	0.093

Releasing Air Charge

⚠ CAUTION

The coil is shipped from the factory pressurized with dry air. Pierce a hole in the coil's rubber plug vapor line seal to relieve the pressure before removing the seal.

NOTE - If there is no pressure release when the coil's liquid line rubber plug seal is pierced, check the coil for leaks before continuing with the installation.

The coil is shipped with a 10 ± 3 psig dry air holding charge. Puncture the suction line rubber plug to release the charge. Remove the rubber plug.

⚠ WARNING

This product and/or the indoor unit it is matched with may contain fiberglass wool.

Disturbing the insulation during installation, maintenance, or repair will expose you to fiberglass wool dust. Breathing this may cause lung cancer. (Fiberglass wool is known to the State of California to cause cancer.)

Fiberglass wool may also cause respiratory, skin, and eye irritation.

To reduce exposure to this substance or for further information, consult material safety data sheets available from OEM or contact your supervisor.

Unit Installation

1. Install the furnace per the installation instructions provided with the unit.
2. Place a field-provided heat shield, such as a wet rag, against the piping plate and around the piping stubs,

and sweat in the suction line. The heat shield must be in place to guard against heat damage to the paint.

NOTE - In areas of high humidity, the suction line section in the air stream in the cabinet should be insulated with foam tape. See figure 1.

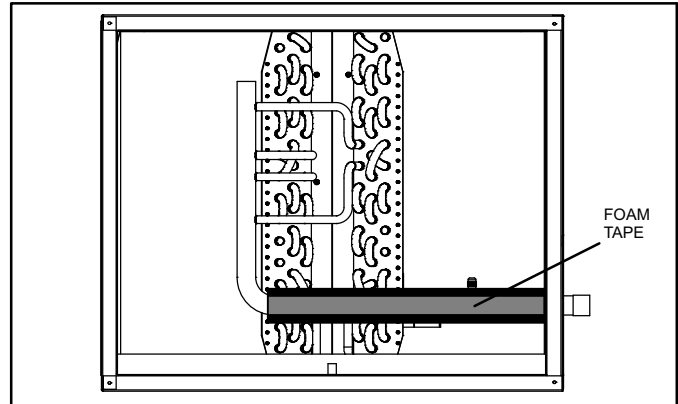

Figure 1. Discharge End of Coil

3. **Left-Hand and Right-Hand Discharge**—The coil must have a 1/2" slope from the rear of the cabinet to the drain. Position the coil adjacent to the furnace cabinet and align the six screw clearance holes in the coil casing with the furnace engagement holes. Use six field-provided #8 X 1" screws to secure the coil casing to the furnace (see figures 2 and 3).
 4. **Right-Hand Air Discharge with Field-Provided Spacer**—The coil must have a 1/2" slope from the rear of the cabinet to the drain. Position the coil in the left-to-right configuration connection on the service access side of the furnace (see figure 4). Position the field-provided spacer between the furnace and the coil. Use field-provided screws to secure the coil casing, spacer and the furnace together. The spacer should be long enough to allow room for proper installation (approximately six inches minimum).
- NOTE: When the coil is connected directly with a condensing furnace, the coil must be level from return end to supply end. The front (access side) of the furnace may be pitched down up to one-inch to accommodate a 1/2" pitched coil.*
5. Secure the supply duct to the coil cabinet.
 6. Refer to the instructions provided with the condensing unit for leak testing, evacuating and charging procedures. **Always check the entire system for leaks before charging.**
 7. **Applications using CH33-62 "D" width unit with "C" width furnace**—Figure 5 shows an application that includes a "D" width coil and a "C" width furnace. This application requires an insulated, field-supplied block-off plate be constructed to cover the open space on the coil housing.

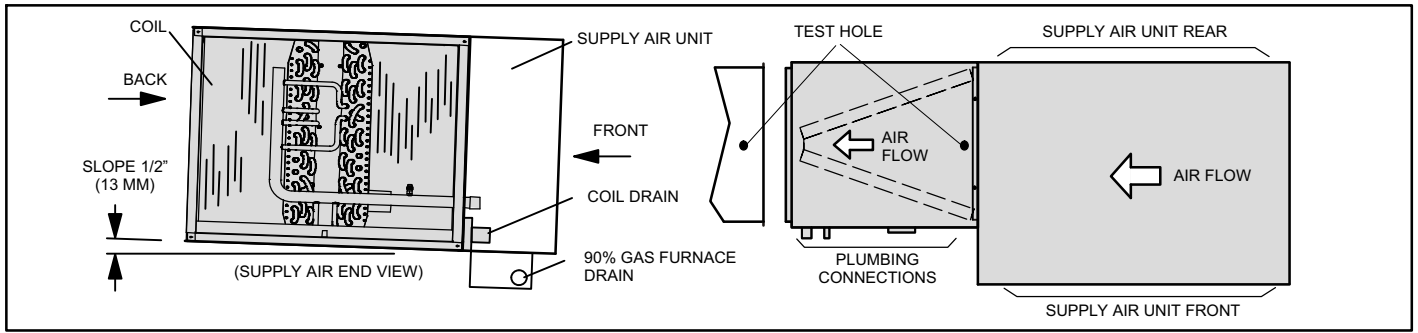
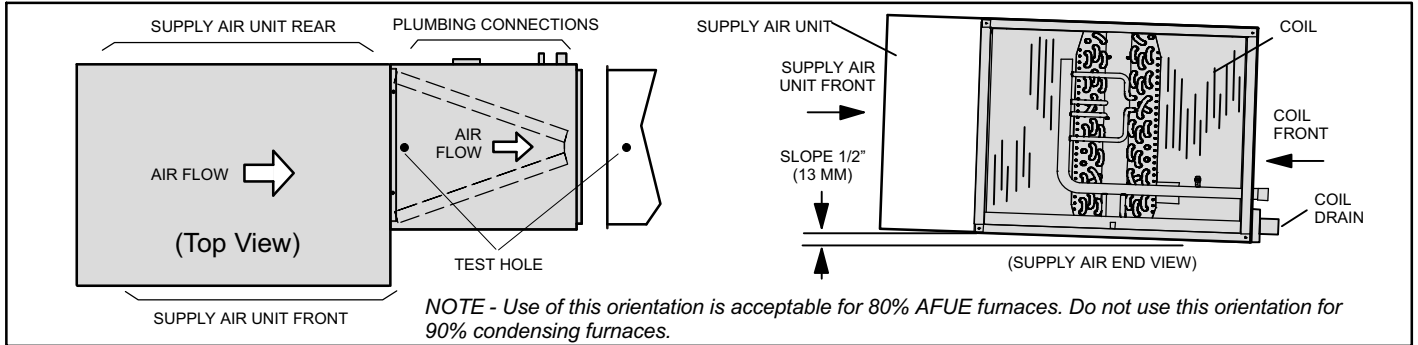

Figure 2. Left-Hand Air Discharge



NOTE - Use of this orientation is acceptable for 80% AFUE furnaces. Do not use this orientation for 90% condensing furnaces.

Figure 3. Right-Hand Air Discharge

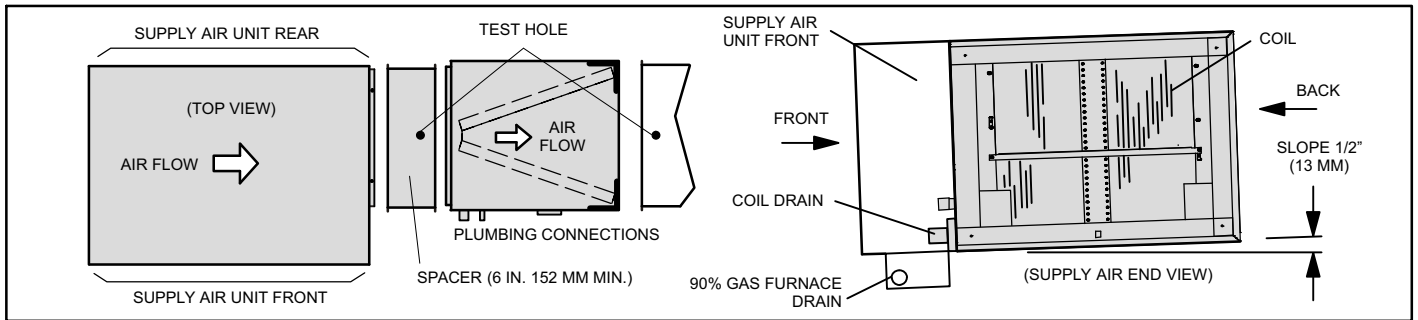

Figure 4. Right-Hand Air Discharge with Spacer

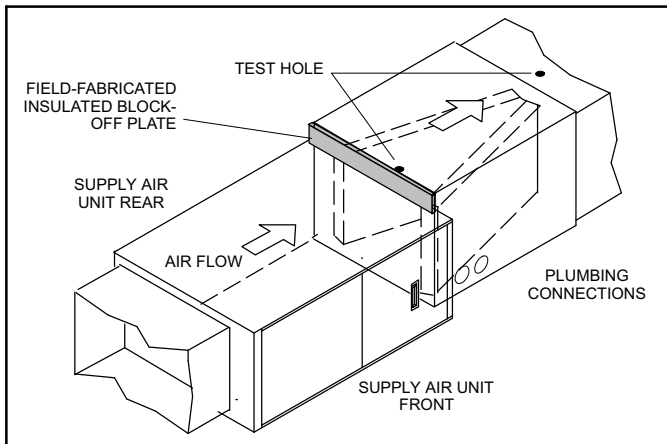

Figure 5. "D" Width Coil w/"C" Width Furnace Leak Testing, Evacuating, Charging - Refer to the instructions provided with the outdoor unit for leak testing, evacuating and charging procedures. **Always leak check entire system before charging.**

Sealing Ducts - Ensure ducts are secured and all joints properly sealed to either the coil cabinet flanges or the furnace cabinet flanges.

⚠ WARNING

There must be an airtight seal between the bottom of the furnace and the return air plenum. Use fiberglass sealing strips, caulking, or equivalent sealing method between the plenum and the air handler cabinet to ensure a tight seal. Return air must not be drawn from a room where this air handler or any gas-fueled appliance (i.e., water heater), or carbon monoxide-producing device (i.e., wood fireplace) is installed.

⚠ IMPORTANT

DUCT SYSTEM SIZING - The duct system should be properly sized and installed according to the ASHRAE Standard Manual D. The supply and return air duct systems should be designed for the cfm and static requirements of the job. Consult the blower performance chart in the unit installation instructions to verify that the blower meets the application requirements.

Refrigerant Line Connections

The refrigerant line sets should be sized according to the recommendations given in the outdoor unit installation instructions. See table 1 for sweat connection sizes. A field-provided adapter may be required to match line set connections.

Table 1. Refrigerant Line Connections

CH33 Model	Suction (Vapor)	Liquid
-18-F -19-F -24/30-F -25-F -31-F -36-F	Line Sweat Size - 3/4 Inch (19mm)	
-42-F -43-F -44/48-F -48-F -49-F -50/60-F -60-F -62-F	Line Sweat Size - 7/8 Inch (22mm)	Line Sweat Size - 3/8 Inch (9.5mm)

Replacement Parts

If replacement parts are necessary, order kit 69J46. The kit includes:

- 10 — Brass nuts for liquid line assemblies
- 20 — Teflon rings
- 10 — Liquid line orifice housings
- 10 — Liquid line assemblies

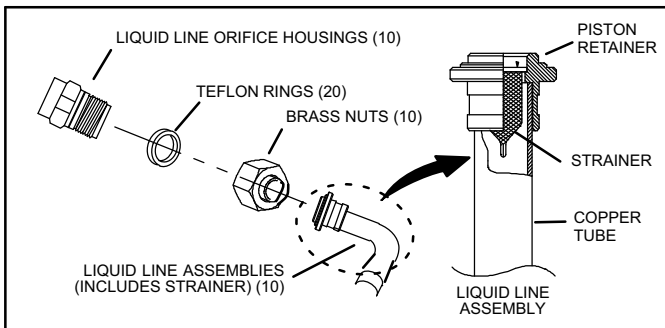

Figure 6. 69J46 Kit Components

Connections

Use a silver alloy brazing rod (5 or 6 percent silver alloy for copper-to-copper connections or 45 percent silver alloy for copper-to-brass or copper-to-steel connections).

BRAZE SUCTION/VAPOR LINE

Use the following procedure to connect the vapor line to the indoor coil unit:

1. Remove rubber plug.
2. Place a field-provided heat shield, such as a wet rag, against the piping plate and around the piping stubs, and sweat in the suction line. The heat shield must be in place to protect the paint from heat damage.
3. Braze connection.
4. Remove the heat shield after brazing and allow the connections to cool.

CONNECT LIQUID LINE

Use the following procedure to connect the liquid line to the indoor coil unit:

1. Slide the liquid line compression nut onto the provided liquid line fitting (the liquid line fitting comes attached to the front of the delta plate of the uncased coils).
2. Insert the field-supplied liquid line into the liquid line stub for brazing.

Refrigerant Metering Device

The CH33 coils are shipped with a factory-installed fixed orifice. CH33 coils are compatible with either HFC-410A fixed orifice or TXV/CTXV metering devices.

The previously reference TXV/CTXV metering devices will be referred to in this instruction as TXV.

DETERMINING CORRECT FIXED ORIFICE

A properly sized fixed orifice may be provided with the outdoor unit. Refer to the outdoor unit instruction to ensure proper sizing of the refrigerant flow control orifice. An improperly sized RFC orifice can lead to diminished capacities and/or efficiencies, as well as potential damage to the unit. RFCs shipped with the units are identified in table 1.

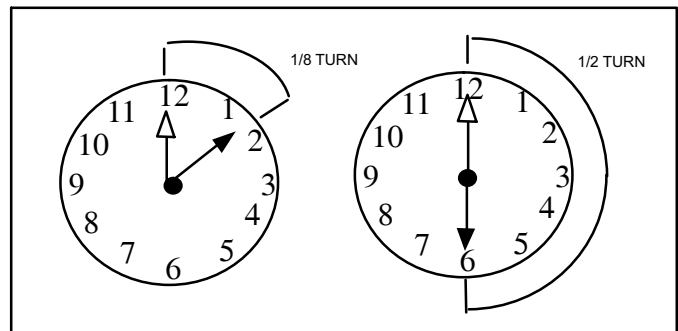

Figure 7. Tightening Distance

TYPICAL FIXED ORIFICE REMOVAL PROCEDURE

1. On fully cased coils, remove the coil access and plumbing panels.
2. Remove any shipping clamps holding the liquid line and distributor assembly.
3. Using two wrenches, disconnect liquid line from distributor. Take care not to twist or damage distributor tubes during this process.
4. Remove and discard orifice, valve stem assembly if present and Teflon ring as illustrated in figure 8.
5. Retain brass nut to be using later with the liquid line assembly.

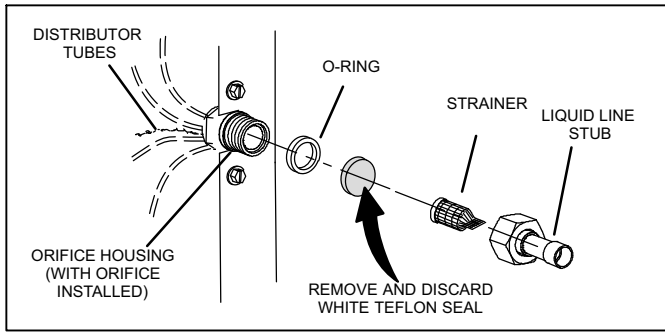

Figure 8. Typical Fixed Orifice Removal

TYPICAL FIXED ORIFICE INSTALLATION PROCEDURE

1. Ensure that the orifice is installed with the nylon seat pointing toward the liquid line orifice housing.
2. Insert the Teflon ring securely into the liquid line orifice housing. Lightly lubricate the threads of the liquid line orifice housing and the expose surface of the Teflon ring.
3. Connect the liquid line assembly with the brass nut to the liquid line orifice housing. Finger tighten and use an appropriately sized wrench to turn an additional 1/2 turn clockwise as illustrated in figure 7, or 20 ft-lb.
4. Place the supplied fixed orifice sticker on the indoor cabinet after installation.

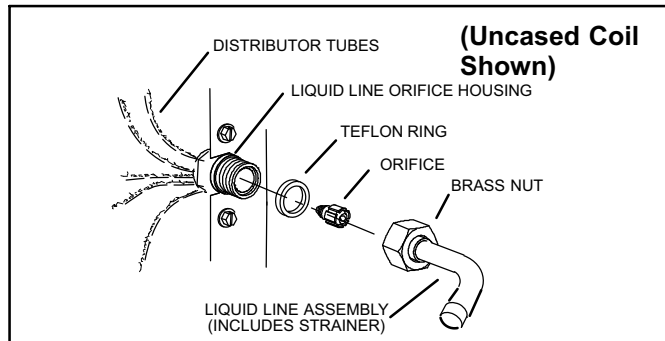

Figure 9. Typical Fixed Orifice Installation

TYPICAL TXV INSTALLATION PROCEDURE

The TXV unit can be installed internal or external to the indoor coil. In applications where an uncased coil is being installed in a field-provided plenum, install the TXV in a manner that will provide access for field servicing of the TXV. Refer to figure 10 for reference during installation of TXV unit.

1. Insert one of the provided Teflon rings into the stubbed end of the TXV. Lightly lubricate the threads of the stubbed end of the TXV and the expose surface of the Teflon ring.
2. Attach the stubbed end of the TXV to the liquid line orifice housing. Finger tighten and use an appropriately sized wrench to turn an additional 1/2 turn clockwise as illustrated in figure 7, or 20 ft-lb.
3. Place the remaining Teflon ring around the other end of the TXV and lightly lubricate the threads of the that end of the TXV, and the expose surface of the Teflon ring.

4. Attach the liquid line assembly with brass nut to the TXV. Finger tighten and use an appropriately sized wrench to turn an additional 1/2 turn clockwise as illustrated in figure 7, or 20 ft-lb.
5. Attach the sensing bulb of the TXV in the proper orientation as illustrated in figure 11 to the suction line using the clamp and screws provided in the TXV kit.

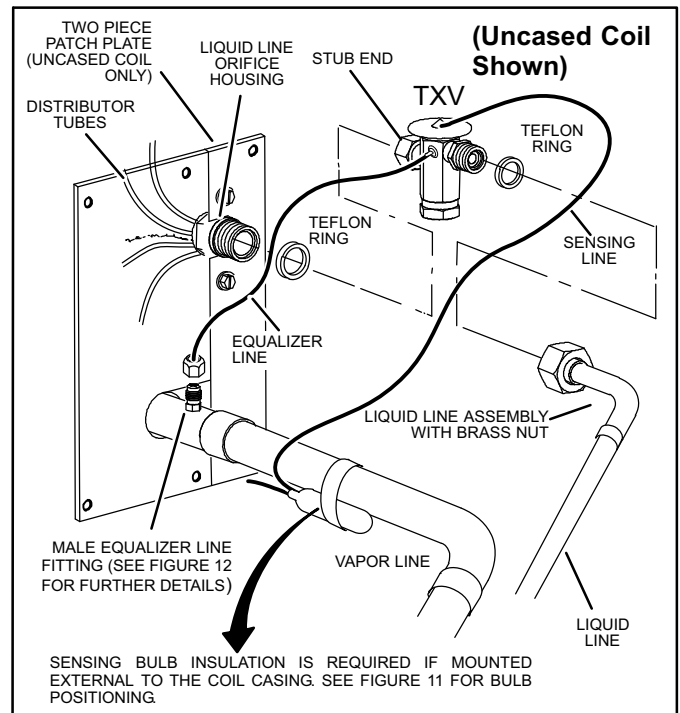

Figure 10. Typical TXV Installation

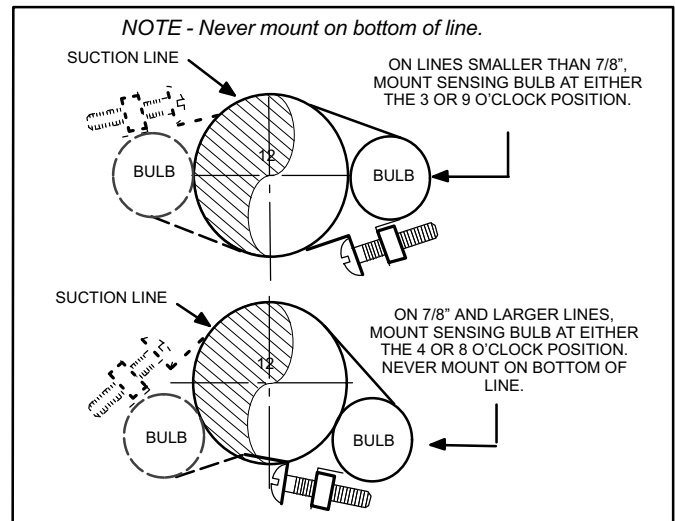

Figure 11. TXV Sensing Bulb Installation

6. Connect the equalizer line from the TXV to the equalizer suction port on the suction line. Finger tighten the flare nut plus 1/8 turn (7 ft-lbs) as illustrated in figure 7.

⚠ IMPORTANT

When removing the flare nut, ensure that the copper flare seal bonnet is removed.

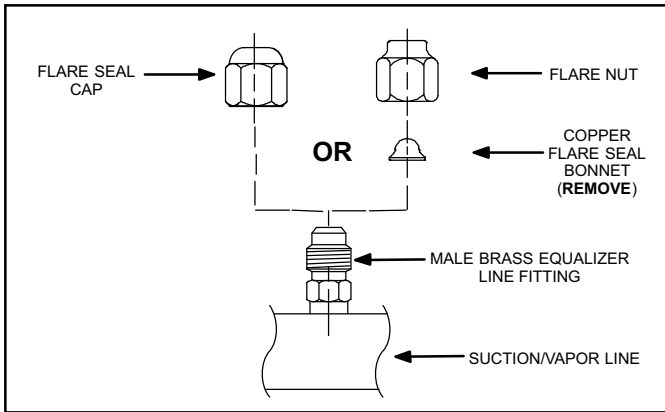

Figure 12. Copper Flare Seal Bonnet Removal

NOTE - To prevent any possibility of water damage, properly insulate all parts of the TXV assembly that may sweat due to temperature differences between the valve and its surrounding ambient temperatures.

See the CH33 Engineering Handbook for approved TXV match-ups and application information. Typically, the TXV kits include the following:

- 1 — TXV
- 2 — Teflon rings
- 1 — 1 1/4" wide copper mounting strap for sensing bulb
- 2 — #10 hex head bolts and nuts for securing sensing bulb

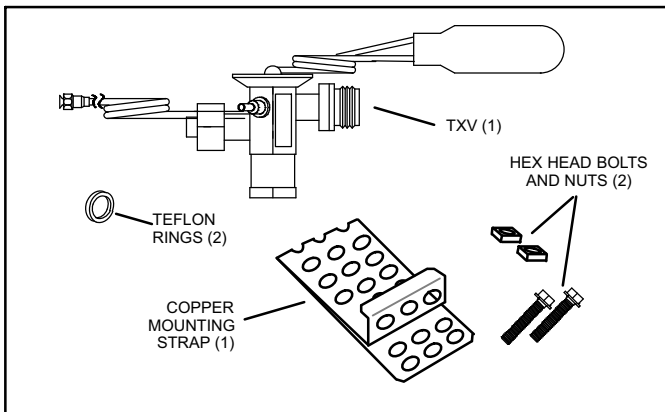

Figure 13. TXV Kit Components

Leak Testing, Evacuating and Charging

Refer to the outdoor unit instruction for leak testing, evacuating and charging procedures. Always leak check entire system before charging.

The following best practices are recommended to ensure better condensate removal:

- Main and overflow drain lines should **NOT** be smaller than both drain connections at drain pan.
- Overflow drain line should run to an area where homeowner will notice drainage.
- It is recommended that the overflow drain line be vented and a trap installed. Refer to local codes.

Sealing Ducts

Ensure the duct is secured and all joints are properly sealed to either the coil cabinet flanges (fully cased models) or the furnace cabinet flanges (uncased models).

⚠ WARNING

There must be an airtight seal between the bottom of the furnace and the return air plenum. Use fiberglass sealing strips, caulking, or equivalent sealing method between the plenum and the air handler cabinet to ensure a tight seal. Return air must not be drawn from a room where this air handler or any gas-fueled appliance (i.e., water heater), or carbon monoxide-producing device (i.e., wood fireplace) is installed.

Condensate Drain Connections

⚠ IMPORTANT

After removal of drain pan plug(s), check drain hole(s) to verify that drain opening is fully open and free of any debris. Also check to make sure that no debris has fallen into the drain pan during installation that may plug up the drain opening.

MAIN DRAIN

Connect the main drain and route downward to drain line or sump. Do not connect drain to a closed waste system. See Figure 14 for typical drain trap configuration.

OVERFLOW DRAIN

It is recommended that the overflow drain is connected to a overflow drain line for all units. If overflow drain is not connected, it must be plugged with provided cap.

BEST PRACTICES

The following best practices are recommended to ensure better condensate removal:

- Main and overflow drain lines should **NOT** be smaller than both drain connections at drain pan.
- Overflow drain line should run to an area where homeowner will notice drainage.
- It is recommended that the overflow drain line be vented and a trap installed. Refer to local codes.

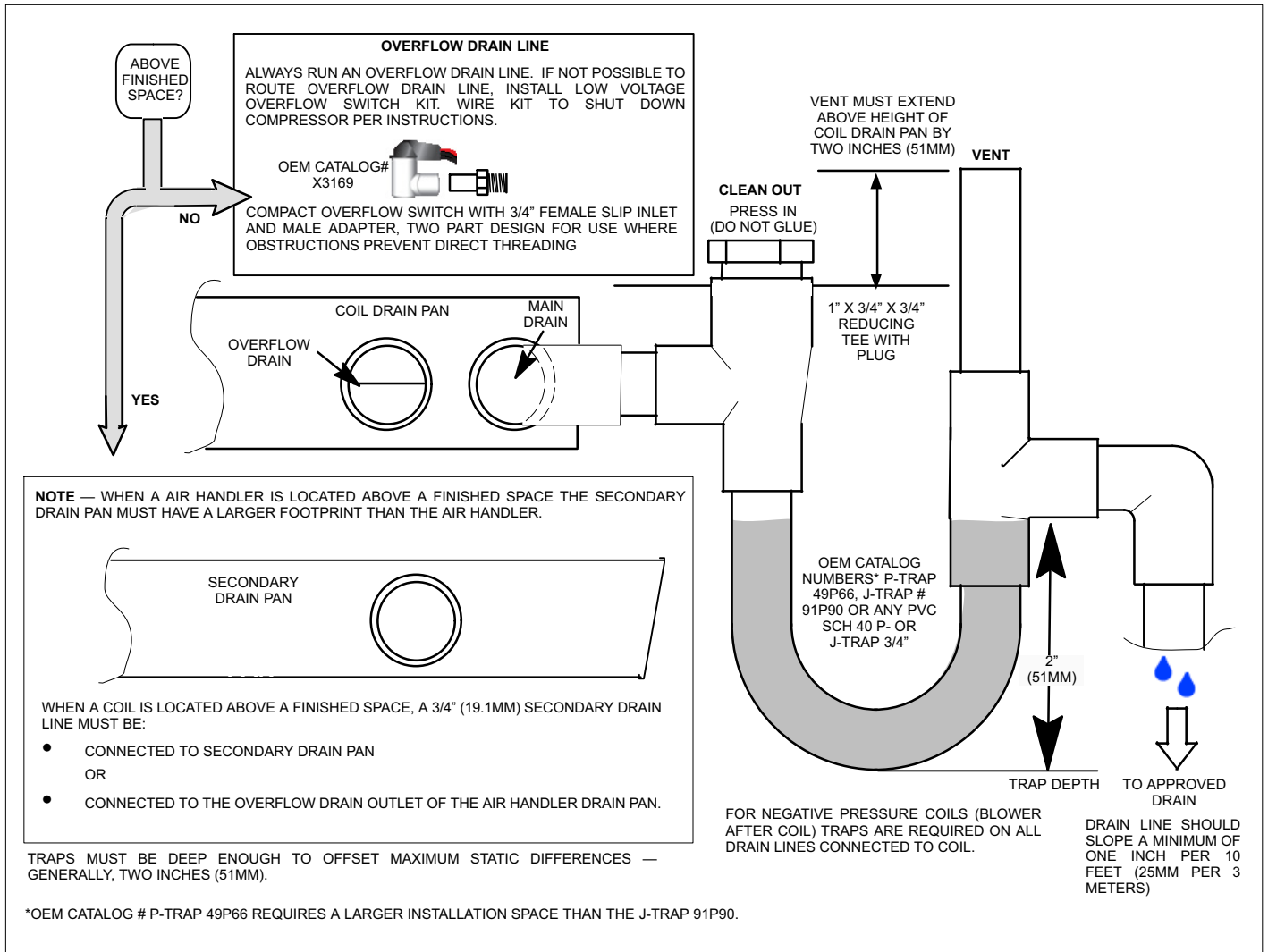

Figure 14. Typical Main and Overflow Drain Installations

Blower Speed Connection

Proper air volume must be provided over the evaporator coil. Select a blower motor speed tap that will provide 400 ± 50 CFM per 12,000 Btuh of cooling capacity (wet coil).

A static pressure reading must be taken to see if the pressure drops are within the proper range. See figure 15 to see for an example to obtain an accurate reading.

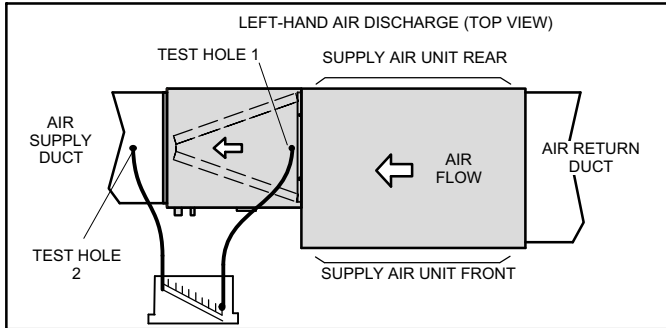

Figure 15. Static Pressure Test

To ensure accuracy, test the air on both sides of the coil (figure 15 exemplifies the two test hole locations).

⚠ CAUTION

Take care when drilling test holes into the furnace flange and the duct. Drill holes away from refrigerant piping. Test holes should be drilled where specified in order to avoid unit damage.

1. Drill a 5/16" (8 mm) test hole in the coil case 1" from the furnace flange (figure 15, test hole 1).
2. Drill a 5/16" (8 mm) test hole into the air supply duct connected to the coil. (test hole 2 in figure 15).
3. Connect the zero end of the draft gauge scale to the furnace end of the coil. Insert the hoses so that 1/4" (6 mm) extends inside the duct or end seal. Seal around holes with Permagum.
4. Turn on the electrical power to the furnace and set the thermostat to initiate a cooling demand.
5. Table 2 lists the range of air volumes and equivalent draft gauge readings for this unit. Observe the draft gauge reading and if below the required air volume, increase the blower speed; if above the required air volume, decrease the blower speed. Refer to the furnace wiring diagram for blower speed settings.
6. When the required draft gauge readings are obtained, remove the draft gauge lines and insert snaphole plugs into the test holes.

Table 2. Air Volume/Static Pressure Drop Across Coil

Model CH33	Cabinet Width in (mm)	Volume: CFM (L/s)	Drop: in. w.g. (Pa) [Dry]	[Wet]
-18-F	14-1/2 (394)	600 (285)	.14 (35)	.17 (42)
-19-F	14-1/2 (394)	800 (380)	.15 (37)	.17 (42)
-25-F	14-1/2 (394)	800 (380)	.15 (37)	.19 (47)
-25-F	17-1/2 (444)	800 (380)	.09 (22)	.11 (27)
-24/30-F	14-1/2 (394)	1000 (470)	.22 (55)	.30 (80)
-31-F	14-1/2 (394)	1000 (470)	.24 (60)	.27 (67)
-31-F	17-1/2 (444)	1000 (470)	.14 (35)	.16 (40)
-36-F	14-1/2 (394)	1200 (565)	.27 (67)	.30 (75)
-36-F	17-1/2 (444)	1200 (565)	.17 (42)	.21 (52)
-36-F	21 (533)	1200 (565)	.17 (42)	.21 (52)
-42-F	17-1/2 (444)	1400 (660)	.22 (55)	.28 (70)
-43-F	14-1/2 (394)	1400 (660)	.26 (65)	.31 (77)
-43-F	17-1/2 (444)	1400 (660)	.18 (45)	.21 (52)
-44/48-F	17-1/2 (444)	1400 (660)	.18 (45)	.23 (57)
-48-F	21 (533)	1600 (755)	.17 (42)	.21 (52)
-49-F	21 (533)	1600 (755)	.25 (62)	.29 (72)
-50/60-F	21 (533)	1600 (755)	.23 (57)	.29 (72)
-60/62-F	24-1/2 (622)	2000 (945)	.21 (52)	.27 (67)

Maintenance

A trained technician or service agency must perform maintenance and service on equipment. At the beginning of each heating or cooling season, indoor coils should be cleaned.

Do not use hydrofluoric acid, alkaline, or similar chemicals on all coils. These chemicals are not necessary to dissolve salt, and may damage the fin coating. Acid washes are used to dissolve oils and greases, which generally are not present on most installations.

Alkaline washes are useful for dissolving oxides such as zinc oxide, aluminum oxide, and iron oxide (rust). These three oxides are more corrosion resistant than base metals, so dissolving or removing them will cause an increase in corrosion.

⚠ CAUTION

A damaged coil fin can affect equipment operation and performance. Do not use flame, high-pressure water, steam, or volatile cleaners on fins or tubing surfaces. If cleaning requires the use of acidic or alkaline cleaners, follow the manufacturer's instructions. Thoroughly flush cleaner from all equipment components. (Be careful to prevent damage or corrosion of the components connected to the system or areas surrounding the equipment being cleaned.)

CLEANING THE COIL:

1. Remove the coil from the cabinet or plenum, and take the coil to an appropriate place to clean it.
2. Vacuum or brush the coil to remove matted and surface debris from the fin. Use vacuum attachments and /or brushes that are non-destructive to fins.

3. If oil deposits are present, spray the coil with ordinary household liquid detergent. Allow detergent to soften deposits. Wait 10 minutes.

NOTE - For units in coastal regions, fresh water will dissolve away any salt deposits. (Wash coils with fresh water at least every six months.)

4. Spray the coil at a vertical angle of 30 to 45 degrees with a constant stream of water at moderate pressure. A pressure washer with a fan nozzle will work best. Do not spray the coil from a horizontal direction.
5. Direct the spray so that any debris is washed out of the coil and basepan. For most residential units, hot water is not necessary.

NOTE - Attempting to back flush from the inside of the coil will require removing parts from the unit, and it may be very

difficult to flush the whole coil surface. Attempting to blow water through a coil will slow the water stream and reduce the flushing action of the outer fin surface.

6. Replace the coil into the cabinet or plenum. Ensure that you have followed the proper procedure for routing and securing the refrigerant tubing.

IMPORTANT

Ensure that the distributor lines are not rubbing together or kinked. All tubes must have enough clearance from other metal parts. Use wire ties to secure tubes to prevent movement that could cause the refrigerant tubing to fail. Adjust the tubes as necessary.

Wires should never touch or be secured to refrigerant lines that will contain hot gas in certain system modes.

