

INSTALLATION MANUAL

MODULATING ECM RESIDENTIAL GAS FURNACES

MODELS: TP9C, YP9C, CP9C, and
LP9C Series

(Up to 98% AFUE Multi-position)



LIST OF SECTIONS

SAFETY	2	START-UP AND ADJUSTMENTS	35
DUCTWORK	5	SAFETY CONTROLS	40
FILTERS	9	NORMAL OPERATION AND DIAGNOSTICS	40
GAS PIPING	10	REPLACEMENT PARTS LIST	42
ELECTRICAL POWER	11	REPLACEMENT PART CONTACT INFORMATION	42
CONDENSATE PIPING AND FURNACE VENTING CONFIGURATION	21	WIRING DIAGRAM	43
COMBUSTION AIR AND VENT SYSTEM	27	START UP SHEET	45

LIST OF FIGURES

Duct Attachment	5	Thermostat Chart - Single Stage Heat Pump – Variable Speed Modulating Furnace	18
Combustible Floor Base Accessory	6	Thermostat Chart - Single Stage Heat Pump – Variable Speed Modulating Furnace	19
Horizontal Application (Typical)	6	Thermostat Chart - Two Stage Heat Pump – Variable Speed Modulating Furnace	20
Typical Attic Installation	6	Typical Condensate Drain, Vertical Installation	22
Typical Suspended Furnace / Crawl Space Installation	7	Upflow Configuration	23
Downflow Venting	7	Downflow Configuration	24
Vertical Applications (Typical)	7	Horizontal Left Configuration	25
Coil Cabinet Attachment Flanges	7	Horizontal Right Configuration	26
Horizontal Right Application (Typical)	8	Dimensions	29
Horizontal Left Application	8	Home Layout	30
PC Series Upflow Coil Installation	8	Termination Configuration - 1 Pipe	31
Horizontal Left or Right application (Right Shown)	8	Termination Configuration - 2 Pipe	31
Dimensions	9	Termination Configuration - 2 Pipe Basement	31
Side Return Cutout Markings	9	Double Horizontal Combustion Air Intake and Vent Termination	32
Gas Valve	10	Double Vertical Combustion Air Intake and Vent Termination	32
Gas Piping	10	Downward Venting	32
Electrical Wiring	12	Direct Vent Air Intake Connection and Vent Connection	32
Furnace Control Board – Communications Connections	13	Combustion Airflow Path Through The Furnace Casing	33
Modulating Furnace with Communicating AC or HP	14	Ambient Combustion Air	33
Modulating Furnace with Communicating Thermostat and Non-Communicating AC	14	Attic and Crawl Space Combustion Air Termination	35
Terminal Screw Wire Connection	14	Gas Valve	37
Thermostat Chart - Single Stage Air Conditioner – Variable Speed Modulating Furnace	15	Furnace Control Board	38
Thermostat Chart - Two Stage Air Conditioner – Variable Speed Modulating Furnace	16	Wiring Diagram	43
Thermostat Chart - Two Stage Air Conditioner with Single Stage Thermostat – Variable Speed Modulating Furnace	17		

LIST OF TABLES

Unit Clearances to Combustibles	4	Combustion Air Intake and Vent Connection Size at Furnace (All Models)	29
Coil Projection Dimensions - PC Series Coils	8	Estimated Free Area	33
Cabinet and Duct Dimensions	9	Unconfined Space Minimum Area	33
Recommended Filter Sizes (High Velocity 600 FPM)	9	Free Area	33
High Altitude Orifices	11	Gas Rate (CU FT/HR) at Full Input	36
Ratings & Physical / Electrical Data	12	Inlet Gas Pressure Range	37
Maximum Equivalent Pipe Length	28	Nominal Manifold Pressure	37
Elbow Dimensions	29	Blower Performance CFM - Any Position	39
Equivalent Length of Fittings	29		

The York YP9C is part of a "Hybrid Comfort System" when paired with a York Heat pump.

These high efficiency, compact units employ induced combustion, reliable hot surface ignition and high heat transfer aluminized tubular heat exchangers. The units are factory shipped for installation in upflow or horizontal applications and may be converted for downflow applications.

These furnaces are designed for residential installation in a basement, closet, alcove, attic, recreation room or garage and are also ideal for commercial applications. All units are factory assembled, wired and tested to assure safe dependable and economical installation and operation.

These units are Category IV listed and may not be common vented with another gas appliance as allowed by the National Fuel Gas Code.

SECTION I: SAFETY



This is a safety alert symbol. When you see this symbol on labels or in manuals, be alert to the potential for personal injury.

Understand and pay particular attention to the signal words **DANGER**, **WARNING**, or **CAUTION**.

DANGER indicates an **imminently** hazardous situation, which, if not avoided, **will result in death or serious injury**.

WARNING indicates a **potentially** hazardous situation, which, if not avoided, **could result in death or serious injury**.

CAUTION indicates a potentially hazardous situation, which, if not avoided **may result in minor or moderate injury**. It is also used to alert against unsafe practices and hazards involving only property damage.

WARNING

*Improper installation may create a condition where the operation of the product could cause personal injury or property damage. Improper installation, adjustment, alteration, service or maintenance can cause injury or property damage. **Failure to carefully read and follow all instructions in this manual can result in furnace malfunction, death, personal injury and/or property damage.** Only a qualified contractor, installer or service agency should install this product.*

SPECIFIC SAFETY RULES AND PRECAUTIONS

1. Only Natural gas or Propane (LP) gas are approved for use with this furnace.
2. Install this furnace only in a location and position as specified in these instructions.
3. A gas-fired furnace for installation in a residential garage must be installed as specified in these instructions.
4. Provide adequate combustion and ventilation air to the furnace space as specified in these instructions.
5. Combustion products must be discharged outdoors. Connect this furnace to an approved vent system only, as specified in SECTION VII of these instructions.
6. Test for gas leaks as specified in these instructions.

WARNING

FIRE OR EXPLOSION HAZARD

Failure to follow the safety warnings exactly could result in serious injury, death or property damage.

Never test for gas leaks with an open flame. Use a commercially available soap solution made specifically for detection of leaks to check all connections. A fire or explosion may result causing property damage, personal injury or loss of life.

7. Always install the furnace to operate within the furnace's intended temperature rise range. Only connect the furnace to a duct system

which has an external static pressure within the allowable range, as specified on the furnace rating plate.

8. When a furnace is installed so that supply ducts carry air circulated by the furnace to areas outside the space containing the furnace, the return air shall also be handled by duct(s) sealed to the furnace casing and terminating outside the space containing the furnace.
9. It is permitted to use the furnace for heating of buildings or structures under construction where the application and use must comply with all manufacturer's installation instructions including:
 - Proper vent installation;
 - Furnace operating under thermostatic control;
 - Return air duct sealed to the furnace;
 - Air filters in place;
 - Set furnace input rate and temperature rise per rating plate marking;
 - Means for providing outdoor air required for combustion;
 - Return air temperature maintained between 55°F (13°C) and 80°F (27°C);
 - The **air filter must be replaced** upon substantial completion of the construction process;
 - Clean furnace, duct work and components upon substantial completion of the construction process, and verify furnace-operating conditions including ignition, input rate, temperature rise and venting, according to the manufacturer's instructions.
10. When installed in a non-HUD-Approved Modular Home or building constructed on-site, combustion air shall not be supplied from occupied spaces.
11. The size of the unit should be based on an acceptable heat loss calculation for the structure. ACCA, Manual J or other approved methods may be used.
12. When moving or handling this furnace prior to installation it is recommended to leave the doors on the furnace to provide support and to prevent damage or warping of the cabinet. When lifting the furnace by the cabinet, support the ends of the furnace rather than lifting by the cabinet flanges at the return air openings (bottom or sides) or supply air opening.
13. When lifting the furnace, it is acceptable to use the primary heat exchanger tubes as a lifting point provided that the tubes are lifted at the front of the heat exchangers where attached to the vestibule panel. Do not use the top return bend of the heat exchangers as lifting points as the tubes may shift out of position or their location brackets/baffles.

IMPORTANT

During installation, doors should remain on the furnace when moving or lifting.

SAFETY REQUIREMENTS

CAUTION

This product must be installed in strict compliance with the installation instructions and any applicable local, state, and national codes including, but not limited to building, electrical, and mechanical codes.

- Refer to the unit rating plate for the furnace model number, and then see the dimensions page of this instruction for return air plenum dimensions in Figure 13. The plenum must be installed according to the instructions.
- Provide clearances from combustible materials as listed under Clearances to Combustibles.
- Provide clearances for servicing ensuring that service access is allowed for both the burners and blower.
- These models **ARE NOT** CSA listed or approved for installation into a **HUD Approved Modular Home** or a **Manufactured (Mobile) Home**.
- This furnace is not approved for installation in trailers or recreational vehicles.

- Furnaces for upflow installation on combustible flooring shall not be installed directly on carpeting, tile or other combustible material other than wood flooring.
- Check the rating plate and power supply to be sure that the electrical characteristics match. All models use nominal 115 VAC, 1 Phase, 60-Hz power supply. **DO NOT CONNECT THIS APPLIANCE TO A 50-Hz POWER SUPPLY OR A VOLTAGE ABOVE 130 VOLTS.**
- Furnace shall be installed so the electrical components are protected from water.
- Installing and servicing heating equipment can be hazardous due to the electrical components and the gas fired components. Only trained and qualified personnel should install, repair, or service gas heating equipment. Untrained service personnel can perform basic maintenance functions such as cleaning and replacing the air filters. When working on heating equipment, observe precautions in the manuals and on the labels attached to the unit and other safety precautions that may apply.

COMBUSTION AIR QUALITY (LIST OF CONTAMINANTS)

The furnace requires **OUTDOOR AIR** for combustion when the furnace is located in any of the following environments.

- Restricted Environments
- Commercial buildings
- Buildings with indoor pools
- Furnaces installed in laundry rooms
- Furnaces installed in hobby or craft rooms
- Furnaces installed near chemical storage areas
- Chemical exposure

The furnace requires **OUTDOOR AIR** for combustion when the furnace is located in an area where the furnace is being exposed to the following substances and / or chemicals.

- Permanent wave solutions
- Chlorinated waxes and cleaners
- Chlorine based swimming pool chemicals
- Water softening chemicals
- De-icing salts or chemicals
- Carbon tetrachloride
- Halogen type refrigerants
- Cleaning solvents (such as perchloroethylene)
- Printing inks, paint removers, varnishes, etc.
- Hydrochloric acid
- Cements and glues
- Antistatic fabric softeners for clothes dryers
- Masonry acid washing materials

When outdoor air is used for combustion, the combustion air intake duct system termination must be located external to the building and in an area where there will be no exposure to the substances listed above.

▲ WARNING

The furnace area must not be used as a broom closet or for any other storage purposes, as a fire hazard may be created. Never store items such as the following on, near or in contact with the furnace.

1. Spray or aerosol cans, rags, brooms, dust mops, vacuum cleaners or other cleaning tools.
2. Soap powders, bleaches, waxes or other cleaning compounds; plastic items or containers; gasoline, kerosene, cigarette lighter fluid, dry cleaning fluids or other volatile fluid.
3. Paint thinners and other painting compounds.
4. Paper bags, boxes or other paper products

Never operate the furnace with the blower door removed. To do so could result in serious personal injury and/or equipment damage.

CODES AND STANDARDS

Follow all national, local codes and standards in addition to this installation manual. The installation must comply with regulations of the serving gas supplier, local building, heating, plumbing, and other codes. In absence of local codes, the installation must comply with the national codes listed below and all authorities having jurisdiction.

In the United States and Canada, follow all codes and standards for the following, using the latest edition available:

STEP 1 -Safety

- US: National Fuel Gas Code (NFGC) NFPA 54/ANSI Z223.1 and the Installation Standards, Warm Air Heating and Air Conditioning Systems ANSI/NFPA 90B
- CANADA: CAN/CGA-B149.1 National Standard of Canada. Natural Gas and Propane Installation Codes (NSCNGPIC)

STEP 2 -General Installation

- US: Current edition of the NFGC and NFPA 90B. For copies, contact the

National Fire Protection Association Inc.
Batterymarch Park
Quincy, MA 02269

or for only the NFGC, contact the
American Gas Association,
400 N. Capital, N.W.
Washington DC 20001

or www.NFPA.org

- CANADA: NSCNGPIC. For a copy contact:
Standard Sales, CSA International
178 Rexdale Boulevard
Etobicoke, (Toronto) Ontario Canada M9W 1RS

STEP 3 -Combustion and Ventilation Air

- US: Section 5.3 of the NFGC, air for Combustion and Ventilation
- CANADA: Part 7 of NSCNGPIC, Venting Systems and Air Supply for Appliances

STEP 4 -Duct Systems

- US and CANADA: Air Conditioning Contractors Association (ACCA) Manual D, Sheet Metal and Air Conditioning Contractors Association National Association (SMACNA), or American Society of Heating, Refrigeration, and Air Conditioning Engineers (ASHRAE) 1997 Fundamentals Handbook Chapter 32.

STEP 5 -Acoustical Lining and Fibrous Glass Duct

- US and CANADA: Current edition of SMACNA and NFPA 90B as tested by UL Standard 181 for Class I Rigid Air Ducts

STEP 6 -Gas Piping and Gas Pipe Pressure Testing

- US: NFGC; chapters 2, 3, 4, & 9 and National Plumbing Codes
- CANADA: NSCNGPIC Part 5

STEP 7 -Electrical Connections

- US: National Electrical Code (NEC) ANSI/NFPA 70
- CANADA: Canadian Electrical Code CSA C22.1

These instructions cover minimum requirements and conform to existing national standards and safety codes. In some instances these instructions exceed certain local codes and ordinances, especially those who have not kept up with changing residential and non-HUD modular home construction practices. These instructions are required as a minimum for a safe installation.

FOR FURNACES INSTALLED IN THE COMMONWEALTH OF MASSACHUSETTS ONLY

For all side wall horizontally vented gas fueled equipment installed in every dwelling, building or structure used in whole or in part for residential purposes, including those owned or operated by the Commonwealth and where the side wall exhaust vent termination is less than seven (7) feet above finished grade in the area of the venting, including but not limited to decks and porches, the following requirements shall be satisfied:

1. **INSTALLATION OF CARBON MONOXIDE DETECTORS.** At the time of installation of the side wall horizontal vented gas fueled equipment, the installing plumber or gasfitter shall observe that a hard wired carbon monoxide detector with an alarm and battery back-up is installed on the floor level where the gas equipment is to be installed. In addition, the installing plumber or gasfitter shall observe that a battery operated or hard wired carbon monoxide detector with an alarm is installed on each additional level of the dwelling, building or structure served by the side wall horizontal vented gas fueled equipment. It shall be the responsibility of the property owner to secure the services of qualified licensed professionals for the installation of hard wired carbon monoxide detectors
 - a. In the event that the side wall horizontally vented gas fueled equipment is installed in a crawl space or an attic, the hard wired carbon monoxide detector with alarm and battery back-up may be installed on the next adjacent floor level.
 - b. In the event that the requirements of this subdivision can not be met at the time of completion of installation, the owner shall have a period of thirty (30) days to comply with the above requirements; provided, however, that during said thirty (30) day period, a battery operated carbon monoxide detector with an alarm shall be installed.
2. **APPROVED CARBON MONOXIDE DETECTORS.** Each carbon monoxide detector as required in accordance with the above provisions shall comply with NFPA 720 and be ANSI/UL 2034 listed and IAS certified.
3. **SIGNAGE.** A metal or plastic identification plate shall be permanently mounted to the exterior of the building at a minimum height of eight (8) feet above grade directly in line with the exhaust vent terminal for the horizontally vented gas fueled heating appliance or equipment. The sign shall read, in print size no less than one-half (1/2) inch in size, "**GAS VENT DIRECTLY BELOW. KEEP CLEAR OF ALL OBSTRUCTIONS**".
4. **INSPECTION.** The state or local gas inspector of the side wall horizontally vented gas fueled equipment shall not approve the installation unless, upon inspection, the inspector observes carbon monoxide detectors and signage installed in accordance with the provisions of 248 CMR 5.08(2)(a)1 through 4.

INSPECTION

As soon as a unit is received, it should be inspected for possible damage during transit. If damage is evident, the extent of the damage should be noted on the carrier's freight bill. A separate request for inspection by the carrier's agent should be made in writing. Also, before installation, the unit should be checked for screws or bolts which may have loosened in transit. There are no shipping or spacer brackets which need to be removed from the interior of this unit.

FURNACE LOCATION AND CLEARANCES

The furnace shall be located using the following guidelines:

1. Where a minimum amount of air intake/vent piping and elbows will be required.
2. As centralized with the air distribution as possible.
3. Where adequate combustion air will be available (particularly when the appliance is not using outdoor combustion air).

4. Where it will not interfere with proper air circulation in the confined space.
5. Where the outdoor vent terminal will not be blocked or restricted. Refer to "VENT CLEARANCES" located in SECTION VII of these instructions. These minimum clearances must be maintained in the installation.
6. Where the unit will be installed in a level position with no more than 1/4" (6.4 mm) slope side-to-side and front-to-back to provide proper condensate drainage.

Installation in freezing temperatures:

1. Furnace shall be installed in an area where ventilation facilities provide for safe limits of ambient temperature under normal operating conditions. Ambient temperatures must not fall below 32°F (0°C) unless the condensate system is protected from freezing.

▲ WARNING

Improper installation in an ambient below 32°F (0°C) could create a hazard, resulting in damage, injury or death.

2. Do not allow return air temperature to be below 55°F (13°C) for extended periods. To do so may cause condensation to occur in the main heat exchanger, leading to premature heat exchanger failure.
3. If this furnace is installed in an unconditioned space and an extended power failure occurs, there will be potential damage to the internal components. Following a power failure situation, do not operate the unit until inspection and repairs are performed.

▲ WARNING

Liquid anti-freeze will cause damage to internal plastic parts of this furnace. DO NOT attempt to winterize the furnace using liquid anti-freeze.

Clearances for access/service:

Ample clearances should be provided to permit easy access to the unit. The following minimum clearances are recommended:

1. Twenty-four (24) inches (61 cm) between the front of the furnace and an adjacent wall or another appliance, when access is required for servicing and cleaning.
2. Eighteen (18) inches (46 cm) at the side where access is required for passage to the front when servicing or for inspection or replacement of flue/vent connections.

In all cases, accessibility clearances shall take precedence over clearances for combustible materials where accessibility clearances are greater.

Installation in a residential garage:

A gas-fired furnace for installation in a residential garage must be installed so the burner(s) and the ignition source are located not less than 18" (46 cm) above the floor, and the furnace must be located or protected to avoid physical damage by vehicles.

Table 1: Unit Clearances to Combustibles

Application	Upflow	Downflow	Horizontal
Top	1"	0"	0"
Vent	0"	0"	0"
Rear	0"	0"	0"
Side	0"	0"	1"
Front ¹	0"	0"	0"
Floor	Combustible	Combustible ²	Combustible
Closet	Yes	Yes	Yes
Line Contact	No	No	Yes

1. Line contact only permitted between lines formed by the intersection of the rear panel and side panel (top in horizontal position) of the furnace jacket and building joists, studs or framing.
2. For combustible floors only when used with special sub-base. All furnaces approved for alcove and attic installation.

SECTION II: DUCTWORK

DUCTWORK GENERAL INFORMATION

The duct system's design and installation must:

1. Handle an air volume appropriate for the served space and within the operating parameters of the furnace specifications.
2. Be installed in accordance of National Fire Protection Association as outlined in NFPA standard 90B (latest editions) or applicable national, provincial, state, and local fire and safety codes.
3. Create a closed duct system. For residential and non-HUD Modular Home installations, when a furnace is installed so that the supply ducts carry air circulated by the furnace to areas outside the space containing the furnace, the return air shall also be handled by a duct(s) sealed to the furnace casing and terminating outside the space containing the furnace.
4. Complete a path for heated or cooled air to circulate through the air conditioning and heating equipment and to and from the conditioned space.

CAUTION

The indoor coil must be installed in the supply air duct, downstream of the furnace. Cooled air may not be passed over the heat exchanger.

When the furnace is used with an indoor coil, the coil must be installed parallel with, or in the supply air side of the furnace to avoid condensation in the primary heat exchanger. When a parallel flow arrangement is used, dampers or other means used to control airflow must be adequate to prevent chilled air from entering the furnace. If manually operated, the damper must be equipped with means to prevent the furnace or the air conditioner from operating unless the damper is in full heat or cool position.

When replacing an existing furnace, if the existing plenum is not the same size as the new furnace then the existing plenum must be removed and a new plenum installed that is the proper size for the new furnace. If the plenum is shorter than 12" (30.5 cm) the turbulent air flow may cause the limit controls not to operate as designed, or the limit controls may not operate at all.

The duct system is a very important part of the installation. **If the duct system is improperly sized the furnace will not operate properly.** The ducts attached to the furnace plenum, should be of sufficient size so that the furnace operates at the specified external static pressure and within the air temperature rise specified on the nameplate.

IMPORTANT

The minimum plenum height is 12" (30.5 cm). The furnace will not operate properly on a shorter plenum height. The minimum recommended rectangular duct height is 4" (10.2 cm) attached to the plenum.

WARNING

The duct system must be properly sized to obtain the correct airflow for the furnace size that is being installed. Refer to the furnace rating plate for the correct rise range and static pressures or to Table 6 for the correct rise range. If the ducts are undersized, the result will be high duct static pressures and/or high temperature rises which can result in a heat exchanger OVERHEATING CONDITION. This condition can result in premature heat exchanger failure, which can result in personal injury, property damage, or death.

If a matching indoor coil is used, it may be placed directly on the furnace outlet and sealed to prevent leakage. If an uncased indoor coil with a thermoplastic drain pan is to be installed in the upflow/horizontal configuration, then extra 2" (5.1 cm) minimum spacing may be needed to ensure against drain pan distortion.

On all installations without a coil, a removable access panel is recommended in the outlet duct such that smoke or reflected light would be observable inside the casing to indicate the presence of leaks in the heat exchanger. This access cover shall be attached in such a manner as to prevent leaks.

DUCT FLANGES

Four flanges are provided to attach ductwork to the furnace. These flanges are rotated down for shipment. In order to use the flanges, remove the screw holding an individual flange, rotate the flange so it is in the upward position and reinstall the screw then repeat this for all 4 flanges.

If the flanges are not used, they must remain in the rotated down position as shipped.

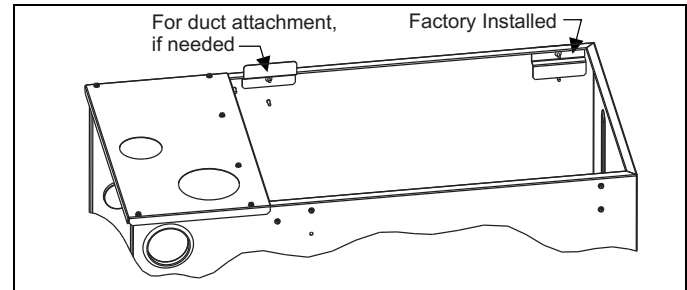
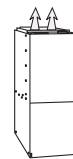

FIGURE 1: Duct Attachment

DUCTWORK INSTALLATION AND SUPPLY PLENUM CONNECTION - UPFLOW/HORIZONTAL



Attach the supply plenum to the furnace outlet. The use of an approved flexible duct connector is recommended on all installations. This connection should be sealed to prevent air leakage. The sheet metal should be crosshatched to eliminate any popping of the sheet metal when the indoor fan is energized.

FLOOR BASE AND DUCTWORK INSTALLATION - DOWNFLOW

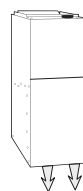

Installations on combustible material or directly on any floors must use a combustible floor base shown in Figure 2. Follow the instructions supplied with the combustible floor base accessory. This combustible floor base can be replaced with a matching indoor coil, properly sealed to prevent leaks. Follow the instructions supplied with the indoor coil cabinet for installing the cabinet to the duct connector. Plug intake and vent pipe holes in bottom panel and move grommet to desired vent side exit.

Downflow Air - Indoor Coil Cabinet

The furnace should be installed with coil cabinet part number specifically intended for downflow application. If a matching indoor coil is used, it may be placed directly on the furnace outlet and sealed to prevent leakage. For details of the coil cabinet dimensions and installation requirements, refer to the installation instructions supplied with the coil cabinet.

Attach the indoor coil cabinet to the duct connector, and then position the furnace on top of the coil cabinet. The connection to the furnace, air conditioning coil cabinet, duct connector, and supply air duct must be sealed to prevent air leakage.

DOWNFLOW DUCT CONNECTORS

All downflow installations must use a suitable duct connector approved by the furnace manufacturer for use with this furnace. The duct connectors are designed to be connected to the rectangular duct under the floor and sealed. Refer to the instructions supplied with the duct connector for proper installation.

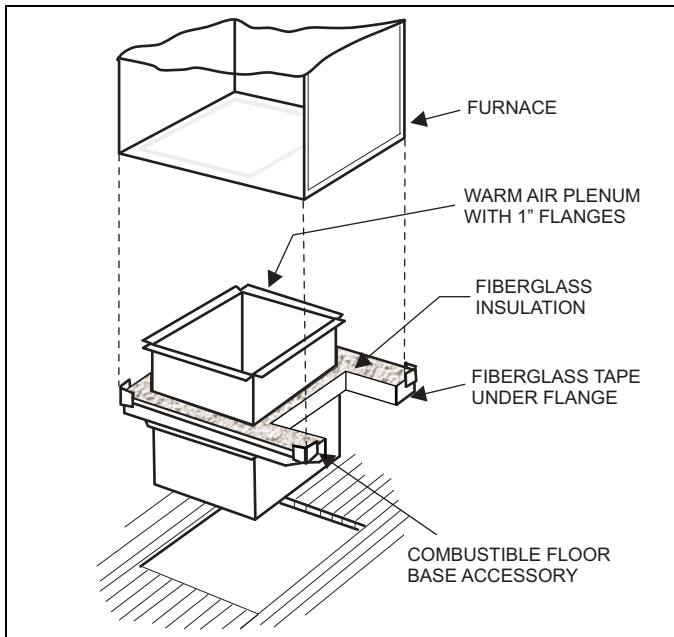

FIGURE 2: Combustible Floor Base Accessory

RESIDENTIAL AND MODULAR HOME UPFLOW RETURN PLENUM CONNECTION

Return air may enter the furnace through the side(s) or bottom depending on the type of application. Return air may not be connected into the rear panel of the unit.

BOTTOM RETURN AND ATTIC INSTALLATIONS

Bottom return applications normally pull return air through a base platform or return air plenum. Be sure the return platform structure or return air plenum is suitable to support the weight of the furnace.

The internal bottom panel must be removed for this application.

Attic installations must meet all minimum clearances to combustibles and have floor support with required service accessibility.

HORIZONTAL APPLICATION

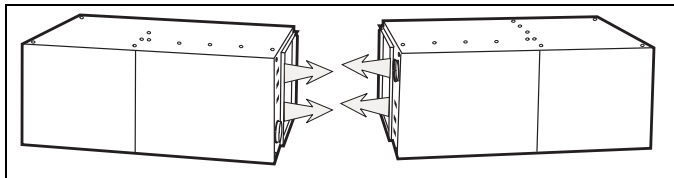

FIGURE 3: Horizontal Application (Typical)

IMPORTANT

*This furnace may be installed in a horizontal position on either side as shown above. **It must not be installed on its back.***

ATTIC INSTALLATION

This appliance is certified for line contact when the furnace is installed in the horizontal left or right position. The line contact is only permissible between lines that are formed by the intersection of the top and the two sides of the furnace and the building joists, studs, or framing. This line may be in contact with combustible material. Refer to Figure 4 for details and additional information.

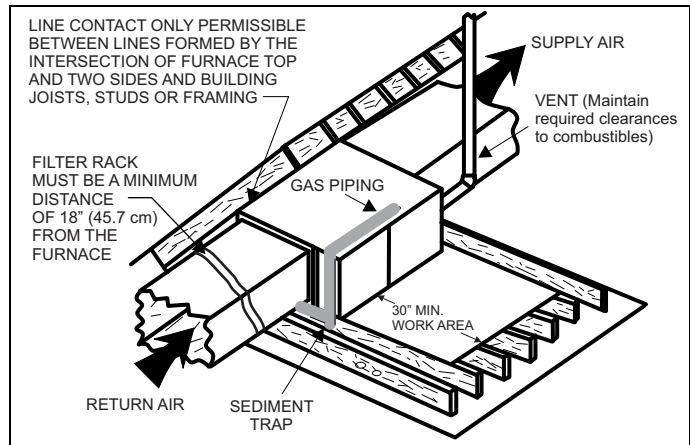

FIGURE 4: Typical Attic Installation

This appliance is certified for line contact when the furnace is installed in the horizontal left or right position. The line contact is only permissible between lines that are formed by the intersection of the top and two sides of the furnace and the building joists, studs or framing. This line may be in contact with combustible material. Refer to Figure 4.

WARNING

When a furnace is installed in an attic or other insulated space, keep all insulating materials at least 12" (30.5 cm) away from furnace and burner combustion air openings.

IMPORTANT

During installation, doors should remain on the furnace when moving or lifting.

When moving or handling this furnace prior to installation it is recommended to leave the doors on the furnace to provide support and to prevent damage or warping of the cabinet. When lifting the furnace, support the ends of the furnace rather than lifting by the cabinet flanges at the return air openings (bottom or sides) or supply air opening.

It is acceptable to use the primary heat exchanger tubes as a lifting point provided that the tubes are lifted at the front of the heat exchangers where attached to the vestibule panel. Do not use the top return bend of the heat exchangers as lifting points as the tubes may shift out of position or their location brackets/baffles.

SUSPENDED FURNACE / CRAWL SPACE INSTALLATION

The furnace can be hung from floor joists or installed on suitable blocks or pads. Blocks or pad installations shall provide adequate height to ensure that the unit will not be subject to water damage.

Units may also be suspended from rafters or floor joists using rods, pipe angle supports or straps. In all cases, the furnace should be supported with rods, straps, or angle supports at three locations to properly support the furnace. Place one support at the supply end of the furnace, one support located approximately in the center of the furnace near the blower shelf, and the third support should be at the return end of the furnace. Maintain a 6" (15.2 cm) minimum clearance between the front of the furnace and the support rods or straps.

All six suspension points must be level to ensure proper and quiet furnace operation. When suspending the furnace, use a secure platform constructed of plywood or other building materials secured to the floor or ceiling joists. Refer to Figure 5 for details and additional information.

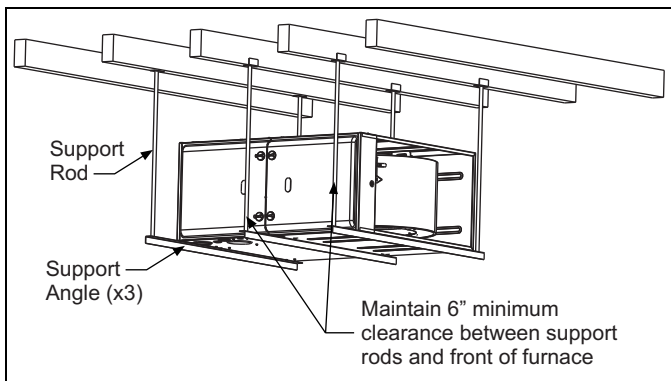

FIGURE 5: Typical Suspended Furnace / Crawl Space Installation

IMPORTANT

During installation, doors should remain on the furnace when moving or lifting.

When moving or handling this furnace prior to installation it is recommended to leave the doors on the furnace to provide support and to prevent damage or warping of the cabinet. When lifting the furnace, support the ends of the furnace rather than lifting by the cabinet flanges at the return air openings (bottom or sides) or supply air opening.

It is acceptable to use the primary heat exchanger tubes as a lifting point provided that the tubes are lifted at the front of the heat exchangers where attached to the vestibule panel. Do not use the top return bend of the heat exchangers as lifting points as the tubes may shift out of position or their location brackets/baffles.

DOWNFLOW APPLICATION

To apply the furnace in a downflow position, it will be necessary to rotate the vent blower 90° left or right so that the vent pipe passes through the side of the furnace casing rather than the end. See Figure 6.

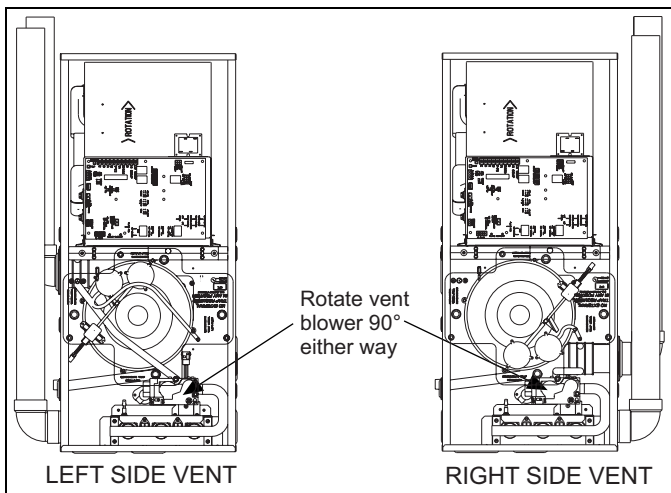

FIGURE 6: Downflow Venting

COIL INSTALLATION

IMPORTANT

On all installations without a coil, a removable access panel is recommended in the outlet duct such that smoke or reflected light would be observable inside the casing to indicate the presence of leaks in the heat exchanger. This access cover shall be attached in such a manner as to prevent leaks.

COIL/FURNACE ASSEMBLY - MC/FC/PC SERIES COILS

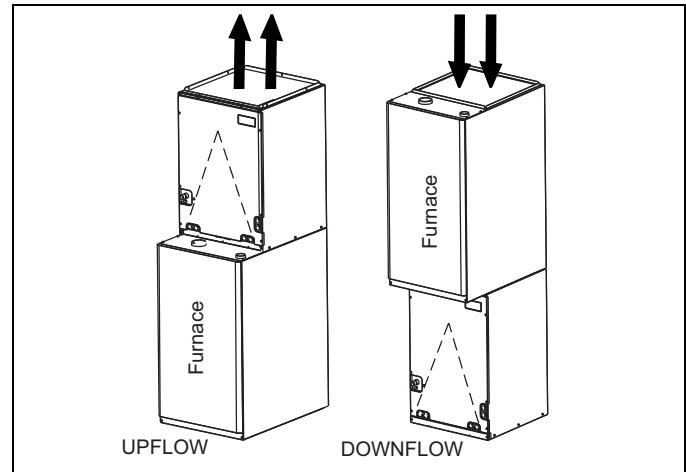

FIGURE 7: Vertical Applications (Typical)

FURNACE ASSEMBLY - MC & FC SERIES COILS

These coils are factory shipped for installation in either upflow or downflow applications with no conversion.

Position the coil casing over or under the furnace opening as shown in Figure 7 after configuring coil flanges as required see "Coil Flange" section below.

COIL FLANGE INSTALLATION

The coil cabinet includes four removable flanges to allow proper fit up with furnaces having inlet and outlet configurations. The flanges are attached to the inside top of the coil cabinet in the factory during production. The flanges are rotated down for shipment. In order to use the flanges, remove the screw holding an individual flange, rotate the flange so it is in the upward position, and reinstall the screw. Repeat the procedure for all 4 flanges. See Figure 8.

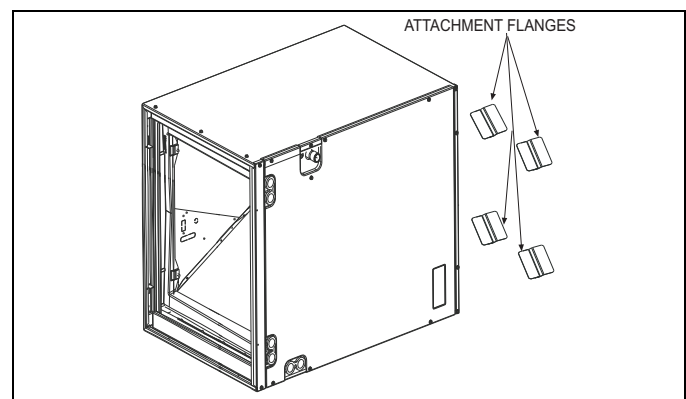

FIGURE 8: Coil Cabinet Attachment Flanges

FURNACE ASSEMBLY - MC SERIES COILS ONLY

MC coils are supplied ready to be installed in a horizontal position. A horizontal pan is factory installed. MC coils should be installed in all horizontal applications with the horizontal drain pan side down.

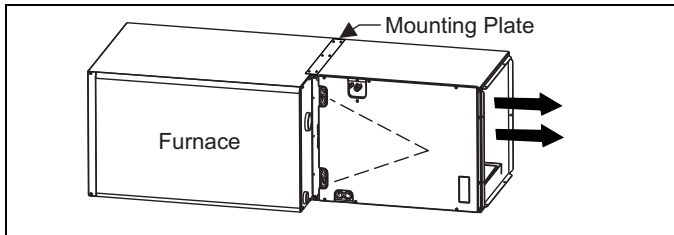

FIGURE 9: Horizontal Right Application (Typical)

For horizontal left hand applications no conversion is required to an MC coil when used with a downflow/horizontal furnace. A mounting plate, supplied with every coil should always be installed on the side designated as top side. See Figures 9 & 10.

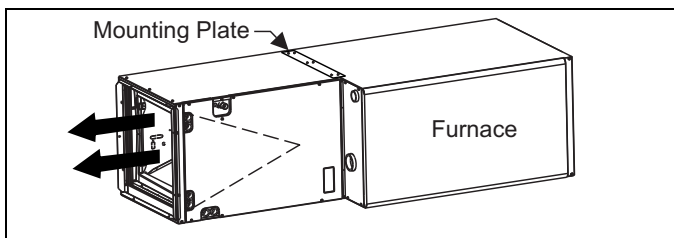

FIGURE 10: Horizontal Left Application

FURNACE ASSEMBLY - PC SERIES COILS

These upflow coils are designed for installation on top of upflow furnaces only.

If the coil is used with a furnace of a different size, use a 45° transition to allow proper air distribution through the coil.

1. Position the coil casing over the furnace opening as shown in Figure 11.
2. Place the ductwork over the coil casing flange and secure.
3. Check for air leakage between the furnace and coil casing and seal appropriately.

CAUTION

Do not drill any holes or drive any screws into the front duct flange on the coil in order to prevent damaging coil tubing. See Figure 11.

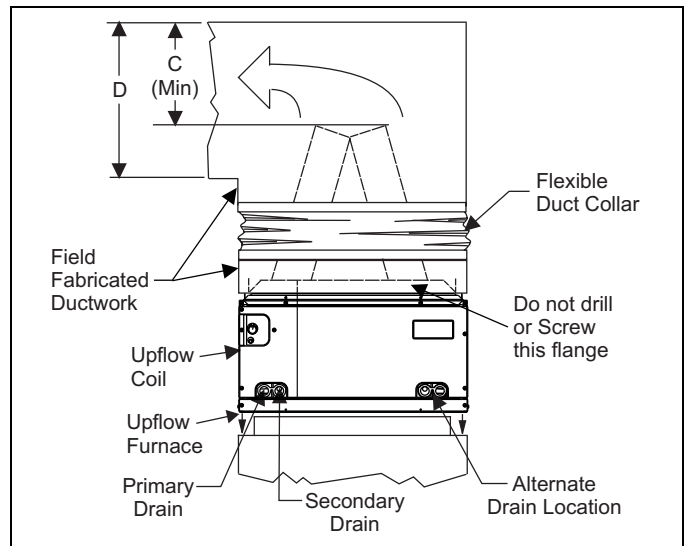

FIGURE 11: PC Series Upflow Coil Installation

Table 2: Coil Projection Dimensions - PC Series Coils

COIL SIZE	DIMENSION "C" INCH
PC18	3-1/2
PC24	4-1/2
PC30, PC32, PC35	4-1/2
PC42, PC43, PC36, PC37	5-1/2
PC48	6-1/2
PC60	9

Dimension "C" should be at least 2/3 of dimension "D". See Figure 11.

CRITICAL COIL PROJECTION

The coil assembly must be located in the duct such that a minimum distance is maintained between the top of the coil and the top of the duct. Refer to Table 2.

COIL / FURNACE ASSEMBLY - HD SERIES COILS

Horizontal duct coils are referred to as HD series coils. This coil must be connected using a supply duct transition. This coil is direction sensitive. Refer to the HD coil installation instructions for more information.

NOTICE

Each coil is shipped with an external tie plate that should be used to secure the coil to the furnace. It should be installed on the back side of the coil using the dimpled pilot holes. See Figure 12.

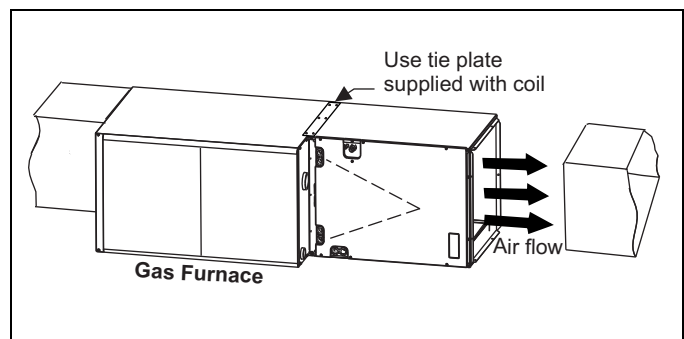

FIGURE 12: Horizontal Left or Right application (Right Shown)

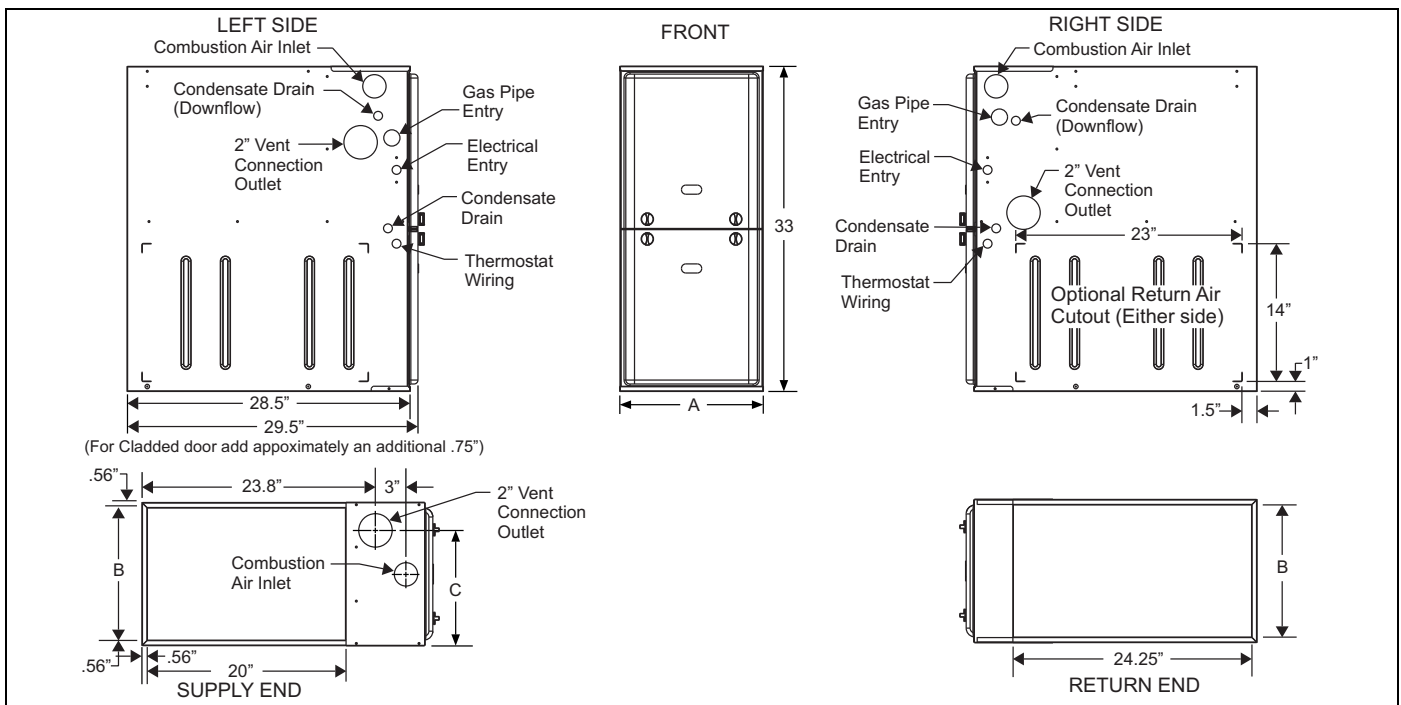

FIGURE 13: Dimensions

Table 3: Cabinet and Duct Dimensions

BTUH (kW) Input	Nominal CFM (m ³ /min)	Cabinet Size	Cabinet Dimensions (Illustrated in Figure 13)					
			A (in)	A (cm)	B (in)	B (cm)	C (in)	C (cm)
60 (17.6)	1200 (34.0)	B	17 1/2	44.4	16 3/8	41.6	13 1/4	33.7
80 (23.4)	1200 (34.0)	B	17 1/2	44.4	16 3/8	41.6	14 3/4	37.5
80 (23.4)	1600 (45.3)	C	21	53.3	19 7/8	50.5	16 1/2	41.9
100 (29.3)	1600 (45.3)	C	21	53.3	19 7/8	50.5	18 1/4	46.4
100 (29.3)	2000 (56.6)	C	21	53.3	19 7/8	50.5	18 1/4	46.4
120 (35.1)	2000 (56.6)	D	24 1/2	62.2	23 3/8	59.4	21 3/4	55.2

SECTION III: FILTERS

FILTER INSTALLATION

All applications require the use of a field installed filter. All filters and mounting provision must be field supplied.

Filters must be installed external to the furnace cabinet. **DO NOT attempt to install filters inside the furnace.**

NOTICE

Single side return above 1800 CFM is approved as long as the filter velocity does not exceed filter manufacturer's recommendation and a transition is used to allow use on a 20x25 filter.

Table 4: Recommended Filter Sizes (High Velocity 600 FPM)

CFM (m ³ /min)	Cabinet Size	Side (in)	Bottom (in)
1200 (34.0)	B	16 x 25	16 x 25
1600 (45.3)	C	16 x 25	20 x 25
2000 (56.6)	C	(2) 16 x 25	20 x 25
2000 (56.6)	D	(2) 16 x 25	22 x 25

- Air velocity through throwaway type filters may not exceed 300 feet per minute (91.4 m/min). All velocities over this require the use of high velocity filters.
- Do not exceed 1800 CFM using a single side return and a 16x25 filter. For CFM greater than 1800, you may use two side returns or one side and the bottom or one side return with a transition to allow use of a 20x25 filter.

SIDE RETURN

Locate the "L" shaped corner locators. These indicate the size of the cutout to be made in the furnace side panel. Refer to Figure 14.

Install the side filter rack following the instructions provided with that accessory. If a filter(s) is provided at another location in the return air system, the ductwork may be directly attached to the furnace side panel.

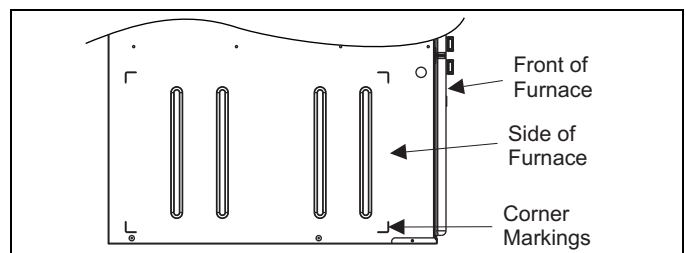

FIGURE 14: Side Return Cutout Markings

IMPORTANT

Some accessories such as electronic air cleaners and pleated media may require a larger side opening. Follow the instructions supplied with that accessory for side opening requirements. **Do not cut the opening larger than the dimensions for the "Optional Return Air Cutout" shown in Figure 13.**

Horizontal Filters

CAUTION

All filters and mounting provision must be field supplied. All installations must have a filter installed.

Any branch duct (rectangular or round duct) attached to the plenum must attach to the vertical plenum before the filter. The use of straps and/or supports is required to support the weight of the external filter box.

Downflow Filters

Downflow furnaces typically are installed with the filters located above the furnace, extending into the return air plenum or duct. Any branch duct (rectangular or round duct) attached to the plenum must attach to the vertical plenum above the filter height.

Filter(s) may be located in the duct system external to the furnace using an external duct filter box attached to the furnace plenum or at the end of the duct in a return filter grille(s). The use of straps and/or supports is required to support the weight of the external filter box.

SECTION IV: GAS PIPING

GAS SAFETY

DANGER

An overpressure protection device, such as a pressure regulator, must be installed in the gas piping system upstream of the furnace and must act to limit the downstream pressure to the gas valve so it does not exceed 0.5 psig [14" w.c. (3.48 kPa)]. Pressures exceeding 0.5 psig [14" w.c. (3.48 kPa)] at the gas valve will cause damage to the gas valve, resulting in a fire or explosion or cause damage to the furnace or some of its components that will result in property damage and loss of life.

IMPORTANT

Plan your gas supply before determining the correct gas pipe entry. Use 90° service elbow(s), or short nipples and conventional 90° elbow(s) to enter through the cabinet access holes.

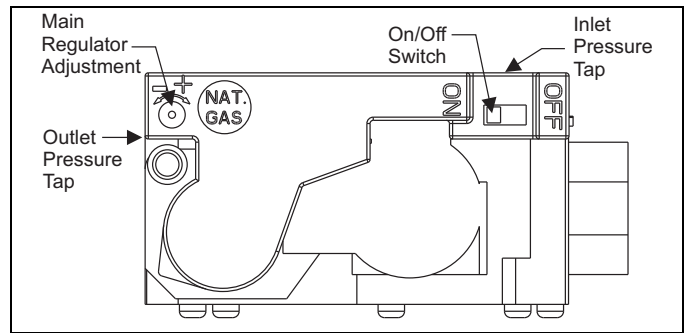

FIGURE 15: Gas Valve

GAS PIPING INSTALLATION

Properly sized wrought iron, approved flexible or steel pipe must be used when making gas connections to the unit. If local codes allow the use of a flexible gas appliance connection, always use a new listed connector. Do not use a connector that has previously serviced another gas appliance.

Some utility companies or local codes require pipe sizes larger than the minimum sizes listed in these instructions and in the codes. The furnace rating plate and the instructions in this section specify the type of gas approved for this furnace - only use those approved gases. The installation of a drip leg and ground union is required. Refer to Figure 16.

IMPORTANT

An accessible manual shutoff valve must be installed upstream of the furnace gas controls and within 6 feet (1.8 m) of the furnace.

The furnace must be isolated from the gas supply piping system by closing its individual external manual shutoff valve during any pressure testing of the gas supply piping system at pressures equal to or less than 0.5 psig (3.5 kPa).

CAUTION

The gas valve body is a very thin casting that cannot take any external pressure. Never apply a pipe wrench to the body of the gas valve when installing piping. A wrench must be placed on the octagon hub located on the gas inlet side of the valve. Placing a wrench to the body of the gas valve will damage the valve causing improper operation and/or the valve to leak.

Gas piping may be connected from either side of the furnace using any of the gas pipe entry knockouts on both sides of the furnace. Refer to Figures 13 and 16.

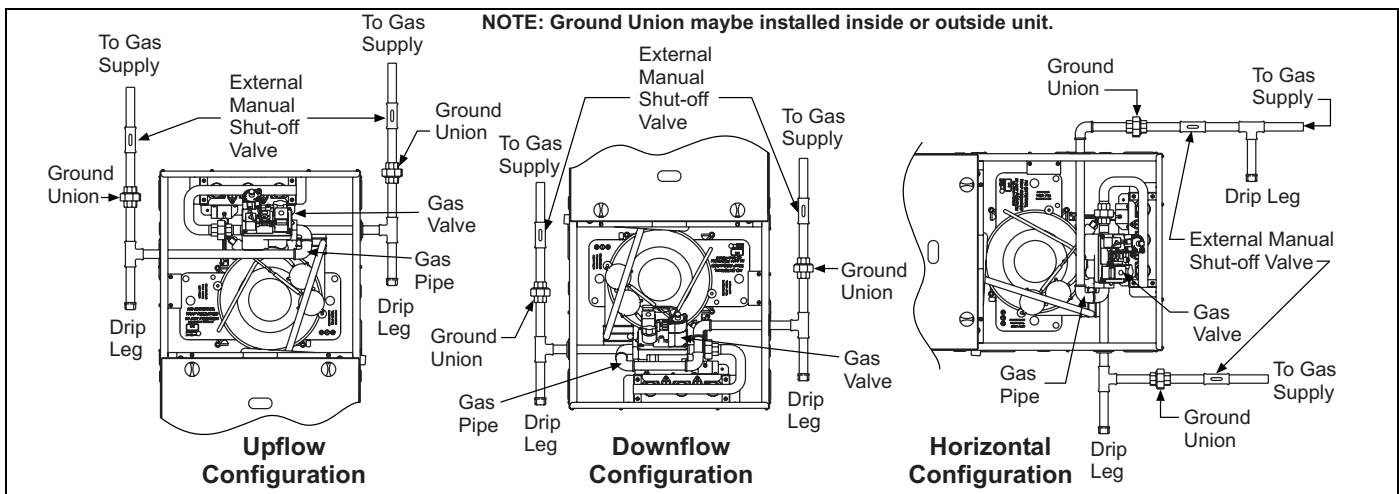

FIGURE 16: Gas Piping

GAS CONVERSION FOR PROPANE (LP)

This furnace is constructed at the factory for natural gas-fired operation, but may be converted to operate on propane (LP) gas by using a factory-supplied LP conversion kit. Follow the instructions supplied with the LP kit.

HIGH ALTITUDE NATURAL GAS ORIFICE CONVERSION

The National Fuel Gas Code requires that gas appliances installed above 2,000 feet elevation have their inputs de-rated by 4% per 1,000 feet above sea level. The modulating furnaces automatically de-rate for altitude by measuring the inducer blower pressure and using that to determine if there is adequate air to support good combustion. If there is not enough combustion air to properly support 100% of the furnace nameplate input rate, the control will reduce the input to the point that there will be good combustion.

The factory gas orifice sizes are based on a gas heating value of 1030 BTU/cu.ft., so if your gas value is significantly higher or lower than that, it may be necessary to change to smaller or larger gas orifices.

The chart below shows recommended gas orifice sizes to use at various altitudes and at various de-ration levels. To use the chart, follow these instructions:

1. Clock the gas meter and calculate the actual input rate using your local gas heating value. See "CALCULATING THE FURNACE INPUT (NAT. GAS)" in this manual.
2. Divide that input rate by the input rate shown on the furnace rating plate to get the actual de-ration percent.
3. Read down the left-hand "Actual Rate" column to find the closest number to your actual de-ration percent.

4. Read across that row to the column for the elevation at your location. The number listed there is the orifice size that is proper for your unit.

Example – You have a 100,000 BTU/H furnace installed at an elevation of 6,000 feet. You clock the gas meter and find that the furnace is actually fired at 64,000 BTU/H. Divide 64,000 by 100,000, which gives 0.64 (64%). The closest number to 64% in the left-hand "Actual Rate" column is 65. Read across that row to the column for 6,000 feet elevation, which shows "#43". You should change from the factory #45 orifices to larger #43 orifices, which will bring the input rate back up to approximately 76,000 BTU/H, which is what it should be for that furnace at 6,000 feet.

Table 5: High Altitude Orifices

Actual Rate (percent of nameplate)	Elevation in Feet Above Sea Level						
	4,000	5,000	6,000	7,000	8,000	9,000	10,000
	84%	80%	76%	72%	68%	64%	60%
	Orifice Drill Size						
100	48	49	49	50	51	51	52
95	47	48	49	50	50	50	51
90	46	47	48	49	49	49	50
85	45	46	47	48	49	49	50
80	45	45	46	47	48	48	49
75	44	45	45	45	47	47	49
70	43	44	44	45	45	45	48
65	42	43	43	44	45	45	47
60	41	42	42	43	44	45	46
55	40	41	41	32	43	43	44
50	39	40	40	40	43	42	42

DANGER

PROPANE KITS

It is very important to choose the correct kit and/or gas orifices for the altitude and the type of gas for which the furnace is being installed.

Only use natural gas in furnaces designed for natural gas. Only use propane (LP) gas for furnaces that have been properly converted to use propane (LP) gas. Do not use this furnace with butane gas.

Incorrect gas orifices or a furnace that has been improperly converted will create an extremely dangerous condition resulting in premature heat exchanger failure, excessive sooting, high levels of carbon monoxide, personal injury, property damage, a fire hazard and/or death.

High altitude and propane (LP) conversions are required in order for the appliance to satisfactorily meet the application.

An authorized distributor or dealer must make all gas conversions.

In Canada, a certified conversion station or other qualified agency, using factory specified and/or approved parts, must perform the conversion.

The installer must take every precaution to insure that the furnace has been converted to the proper gas orifice size when the furnace is installed. Do not attempt to drill out any orifices to obtain the proper orifice size. Drilling out a gas orifice will cause misalignment of the burner flames, causing premature heat exchanger burnout, high levels of carbon monoxide, excessive sooting, a fire hazard, personal injury, property damage and/or death.

SECTION V: ELECTRICAL POWER

ELECTRICAL POWER CONNECTIONS

Field wiring to the unit must be grounded. Electric wires that are field installed shall conform to the temperature limitation for 63°F (35°C) rise wire when installed in accordance with instructions. Refer to Table 6 in these instructions for specific furnace electrical data.

CAUTION

Use copper conductors only.

Table 6: Ratings & Physical / Electrical Data

BTUH/ Cabinet/CFM	Input Max/Min		Output Max/Min		Nominal Airflow		Air Temp. Rise Max Input		Air Temp. Rise Min Input	
	MBH	kW	MBH	kW	CFM	m ³ /min	°F	°C	°F	°C
60B12	60/21	17.6/6.2	58/20	17.0/5.9	1200	34.0	40-70	22-39	20-50	11-28
80B12	80/28	23.4/8.2	77/27	22.6/7.9	1200	34.0	40-70	22-39	20-50	11-28
80C16	80/28	23.4/8.2	78/27	22.8/7.9	1600	45.3	40-70	22-39	20-50	11-28
100C16	100/35	29.3/10.2	97/34	28.4/10.0	1600	45.3	40-70	22-39	20-50	11-28
100C20	100/35	29.3/10.2	97/34	28.4/10.0	2000	56.6	45-75	25-42	25-55	13-31
120D20	120/42	35.1/12.3	116/40	34.0/11.7	2000	56.6	45-75	25-42	25-55	13-31

BTUH Cabinet/CFM	Max. Outlet Air Temp		Blower		Blower Wheel Size	AFUE %	Max Over-Current Protect	Total Unit Amps	Min. wire Size (awg) @ 75 ft one way	Approximate Operating Wgt. Lbs (kg)
	°F	°C	HP	Amps						
60B12	170	76.7	1/2	4.8	11 x 8	97.5	15	7.0	14	113 (51)
80B12	175	79.4	1/2	4.8	11 x 8	97.5	15	7.5	14	119 (54)
80C16	175	79.4	3/4	7.5	11 x 10	97.7	15	10.0	14	134 (61)
100C16	175	79.4	3/4	7.5	11 x 10	97.7	15	10.0	14	140 (64)
100C20	180	82.2	1	14.5	11 x 11	97.7	20	12.0	12	143 (65)
120D20	180	82.2	1	14.5	11 x 11	98.0	20	12.0	12	152 (69)

Annual Fuel Utilization Efficiency (AFUE) numbers are determined in accordance with DOE Test procedures.
 Wire size and over current protection must comply with the National Electrical Code (NFPA-70-latest edition) and all local codes.
 The furnace shall be installed so that the electrical components are protected from water.

SUPPLY VOLTAGE CONNECTIONS

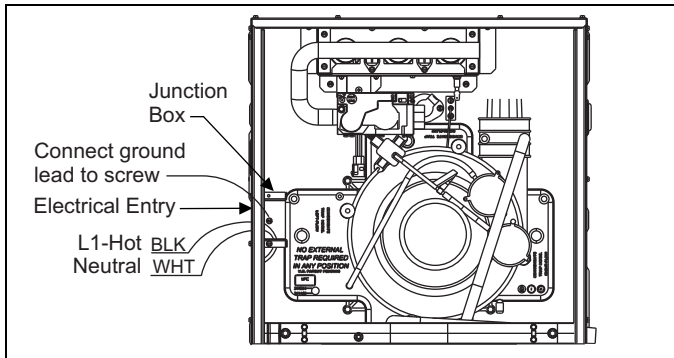

FIGURE 17: Electrical Wiring

1. Provide a power supply separate from all other circuits. Install overcurrent protection and disconnect switch per local/national electrical codes. The switch should be close to the unit for convenience in servicing. With the disconnect or fused switch in the OFF position, check all wiring against the unit wiring label. Refer to the wiring diagram in this instruction.

- Remove the screws retaining the wiring box cover. Route the power wiring through the opening in the unit into the junction box with a conduit connector or other proper connection. In the junction box there will be 3 wires, a Black Wire, a White Wire. Connect the power supply as shown on the unit-wiring label on the inside of the blower compartment door or the wiring schematic in this section. The black furnace lead must be connected to the L1 (hot) wire from the power supply. The white furnace screw must be connected to neutral. Connect the power supply ground to the green screw (equipment ground) An alternate wiring method is to use a field provided 2" (5.1 cm) x 4" (10.2 cm) box and cover on the outside of the furnace. Route the furnace leads into the box using a protective bushing where the wires pass through the furnace panel. After making the wiring connections replace the wiring box cover and screws. Refer to Figure 17.
- The furnace's control system requires correct polarity of the power supply and a proper ground connection. Refer to Figure 17.

IMPORTANT

The power connection leads and wiring box may be relocated to the opposite side of the furnace. Remove the screws and cut wire tie holding excess wiring. Reposition on the opposite side of the furnace and fasten using holes provided.

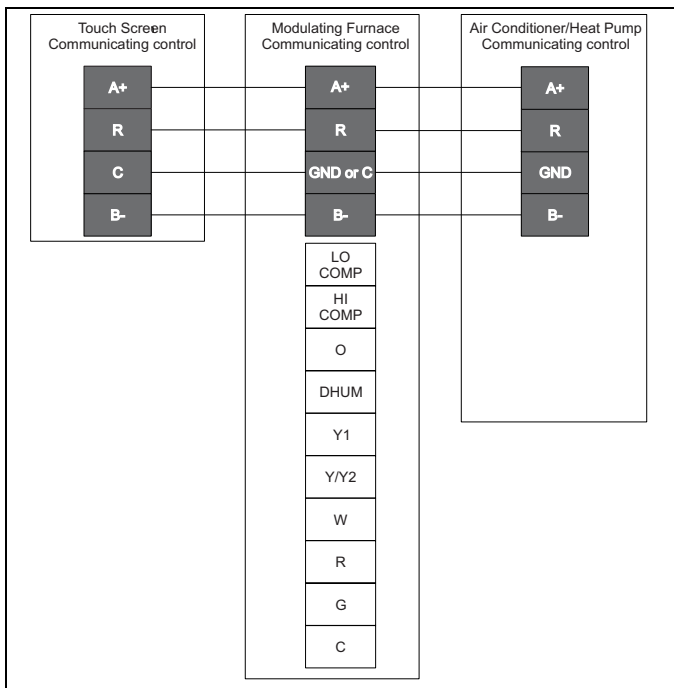

FIGURE 19: Modulating Furnace with Communicating AC or HP

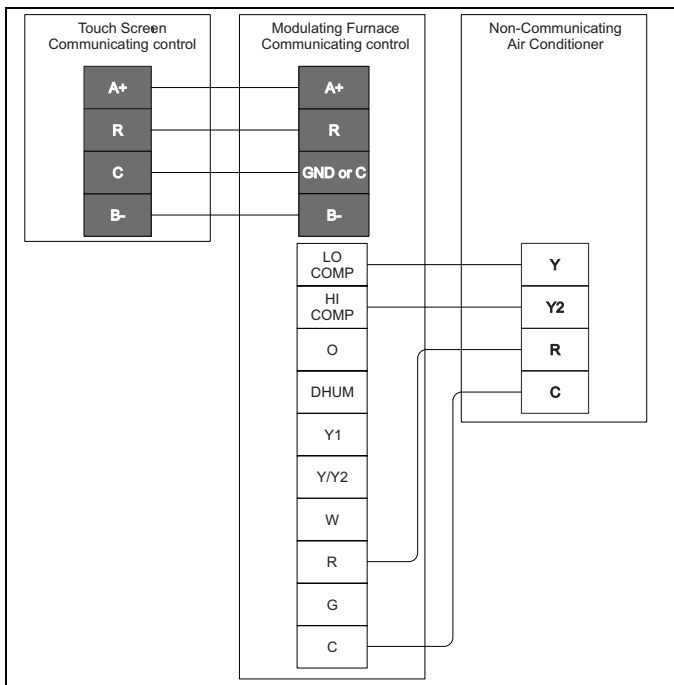

FIGURE 20: Modulating Furnace with Communicating Thermostat and Non-Communicating AC

IMPORTANT

Do not place more than one wire under any single communication terminal screw (there are four communication terminal screws). If more than one wire must be connected to a terminal screw, attach only the terminal end of a one wire pigtail no longer than 6", and use a wire connector to connect the other end of the pigtail to the other wires. Failure to do this will result in nuisance communication error faults. See Figure 21.

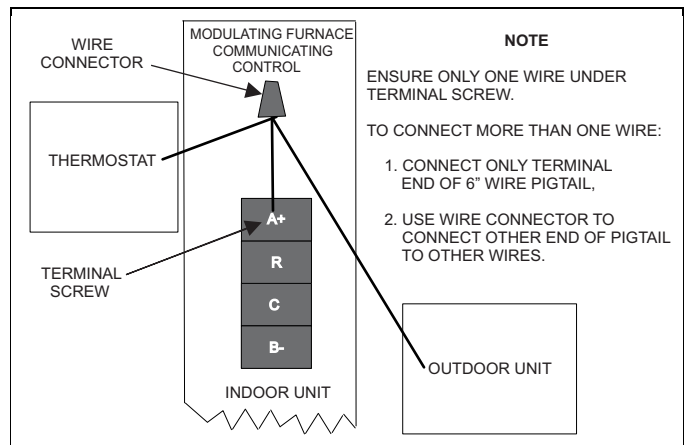

FIGURE 21: Terminal Screw Wire Connection

When connecting the Communicating Control (wall thermostat) and furnace control to a non-communicating outdoor A/C or heat pump, use the wiring diagram in Figure 20. The thermostat and furnace will be connected exactly as shown above, but the conventional 24 volt R, C and Y/Y2 terminals will be used to control the outdoor unit.

CONVENTIONAL LOW VOLTAGE CONTROL WIRING CONNECTIONS

Install the field-supplied thermostat by following the instructions that come with the thermostat. With the thermostat set in the OFF position and the main electrical source disconnected, connect the thermostat wiring from the wiring connections on the thermostat to the terminal board on the ignition module, as shown in Figures 22-27. Electronic thermostats may require the common wire to be connected. Apply strain relief to thermostat wires passing through cabinet. If air conditioning equipment is installed, use thermostat wiring to connect the Y and C terminals on the furnace control board to the proper wires on the condensing unit (unit outside).

IMPORTANT

Set the heat anticipator in the room thermostat to 0.1 amps. Setting it lower will cause short cycles. Setting it higher will cause the room temperature to exceed the set points.

IMPORTANT

Some electronic thermostats do not have adjustable heat anticipators. They should be set to six cycles per hour. Follow the thermostat manufacturer's instructions.

The 24-volt, 40 VA transformer is sized for the furnace components only, and should not be connected to power auxiliary devices such as humidifiers, air cleaners, etc. The transformer may provide power for an air conditioning unit contactor.

AIR CONDITIONER CONNECTIONS

This furnace may be used with single-stage or two-stage air conditioning units.

For Single-Stage A/C - Connect the low voltage wiring as shown in Figure 22.

For Two-Stage A/C - Use a two-stage thermostat, connect the low voltage wiring as shown in Figure 23.

For Two-Stage A/C using a Single-Stage Thermostat - connect the low voltage wiring as shown in Figure 24.

This furnace control board can control a two-stage A/C using only a single-stage thermostat. In this case, the furnace control switches between high cool and low cool based on the calculated cooling load.

For additional connection diagrams for all UPG equipment refer to "Low Voltage System Wiring" document available online at www.upgnet.com in the Product Catalog Section.

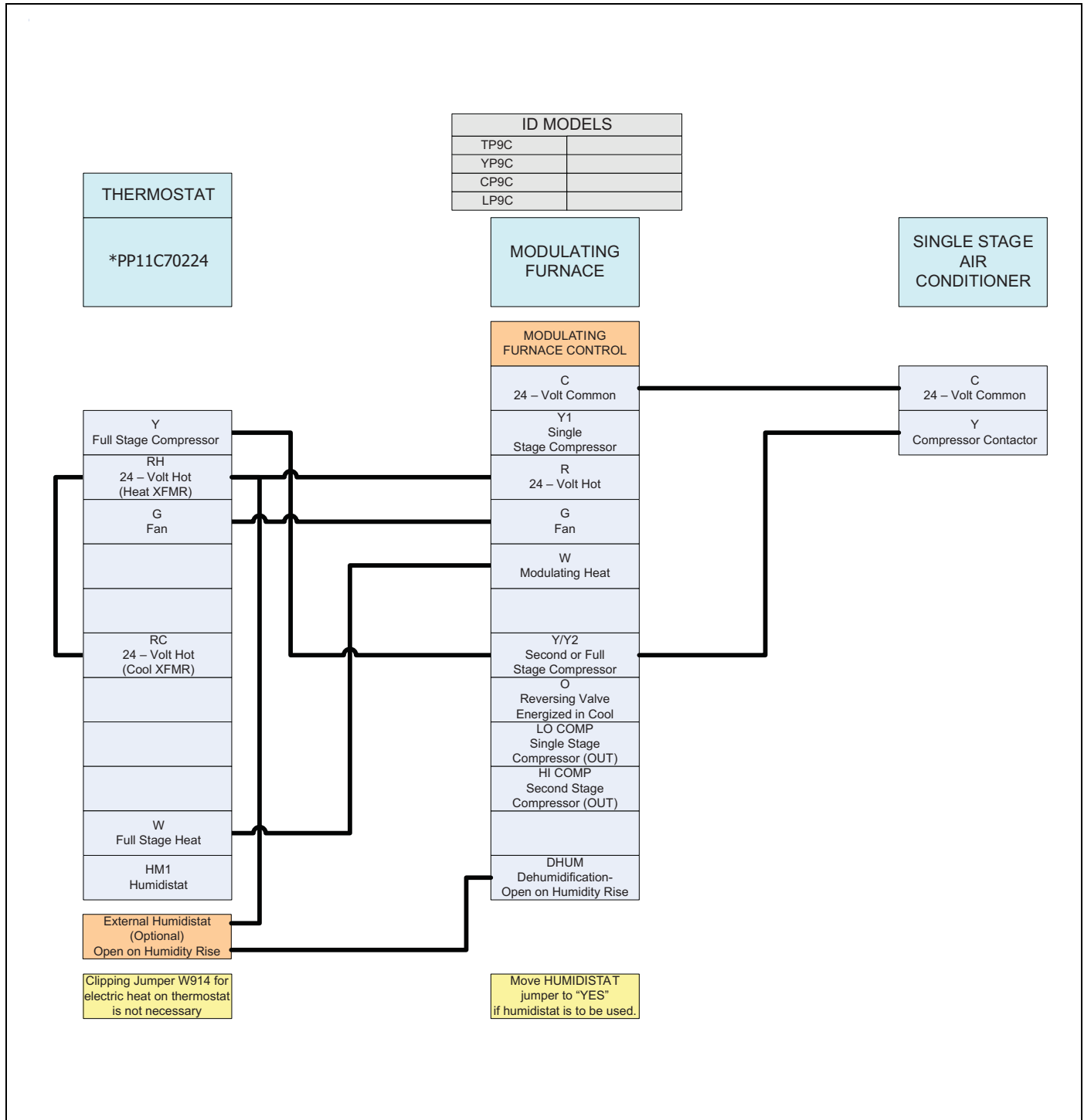

FIGURE 22: Thermostat Chart - Single Stage Air Conditioner – Variable Speed Modulating Furnace

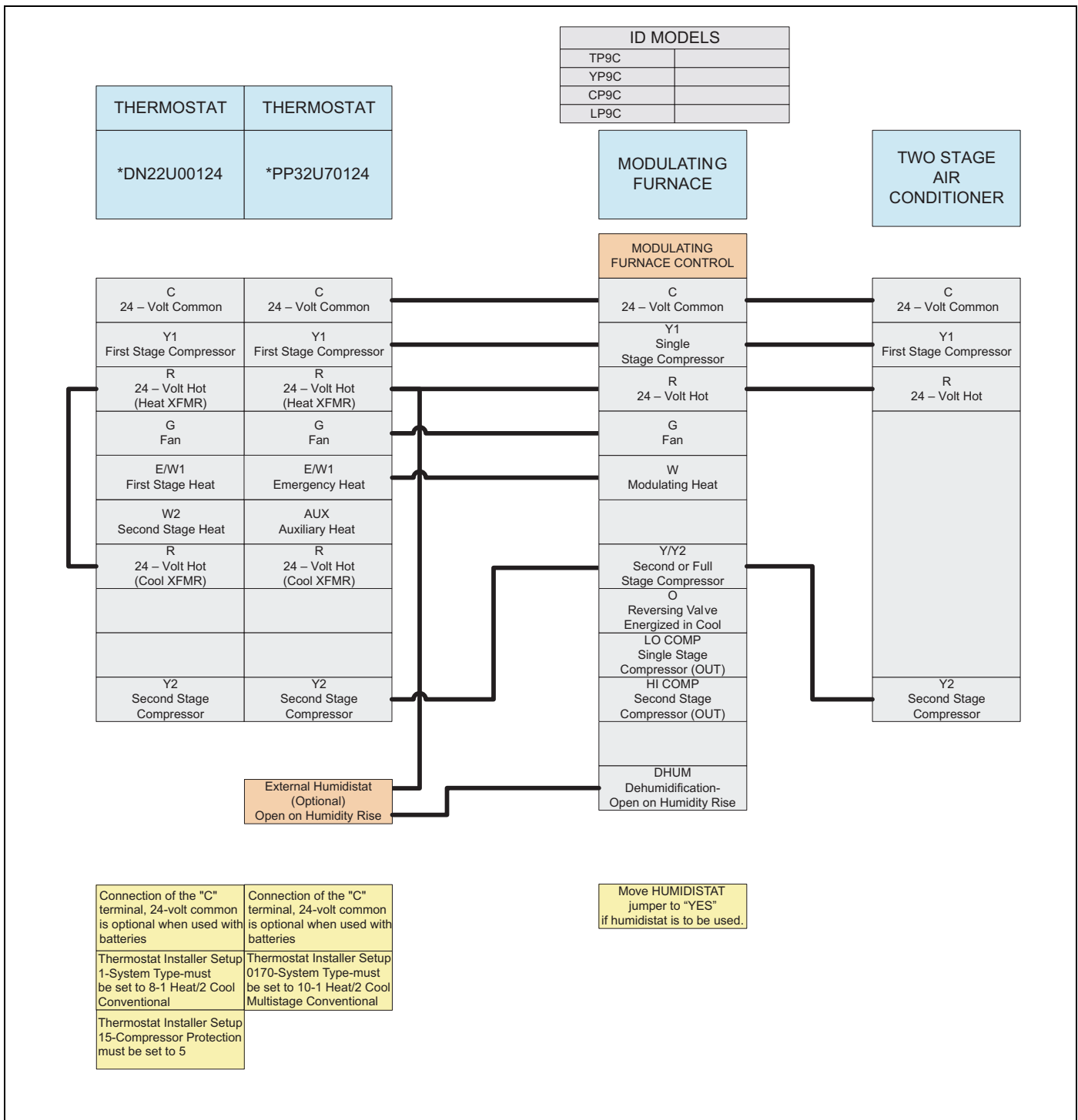

FIGURE 23: Thermostat Chart - Two Stage Air Conditioner – Variable Speed Modulating Furnace

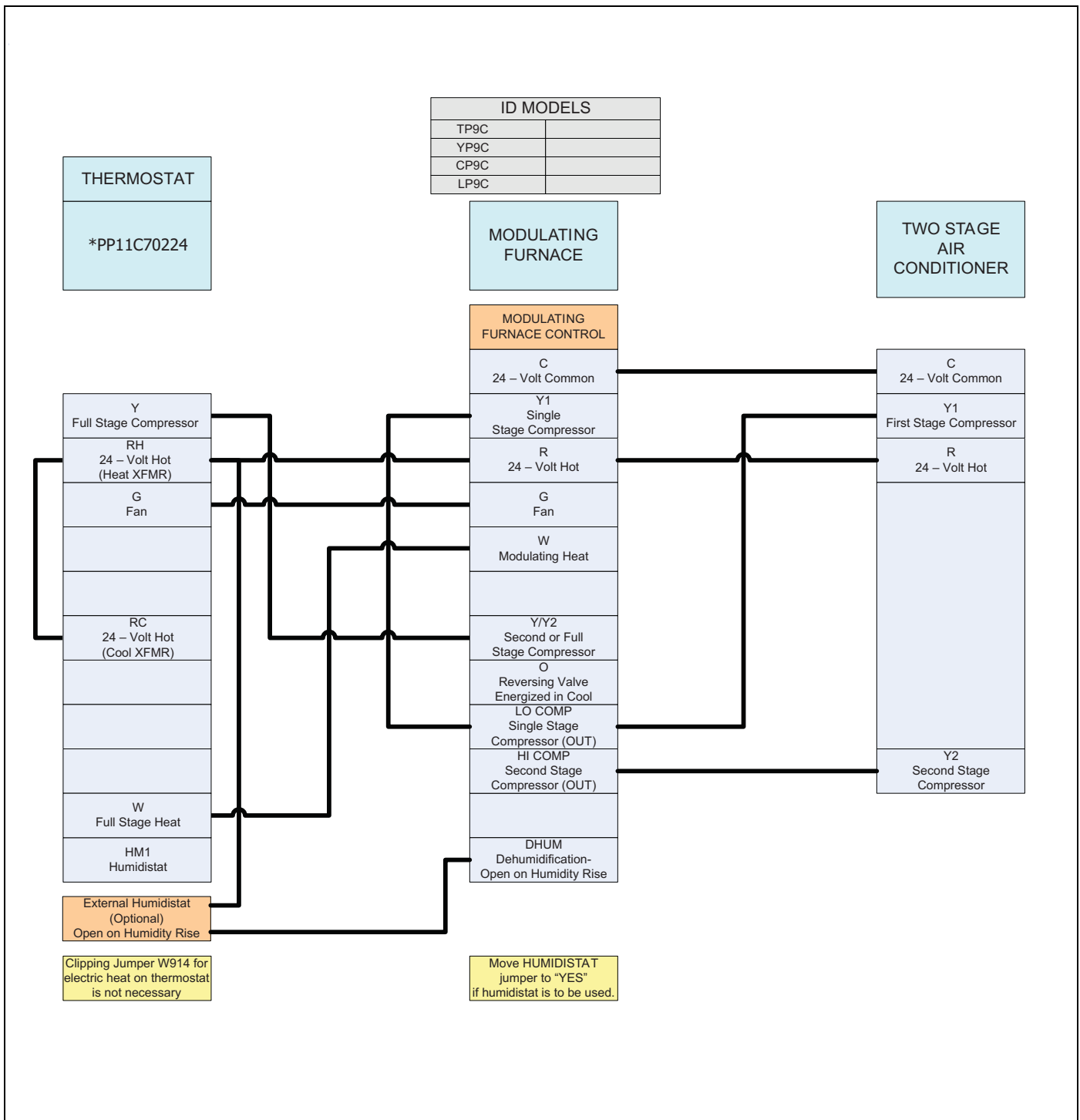

FIGURE 24: Thermostat Chart - Two Stage Air Conditioner with Single Stage Thermostat – Variable Speed Modulating Furnace

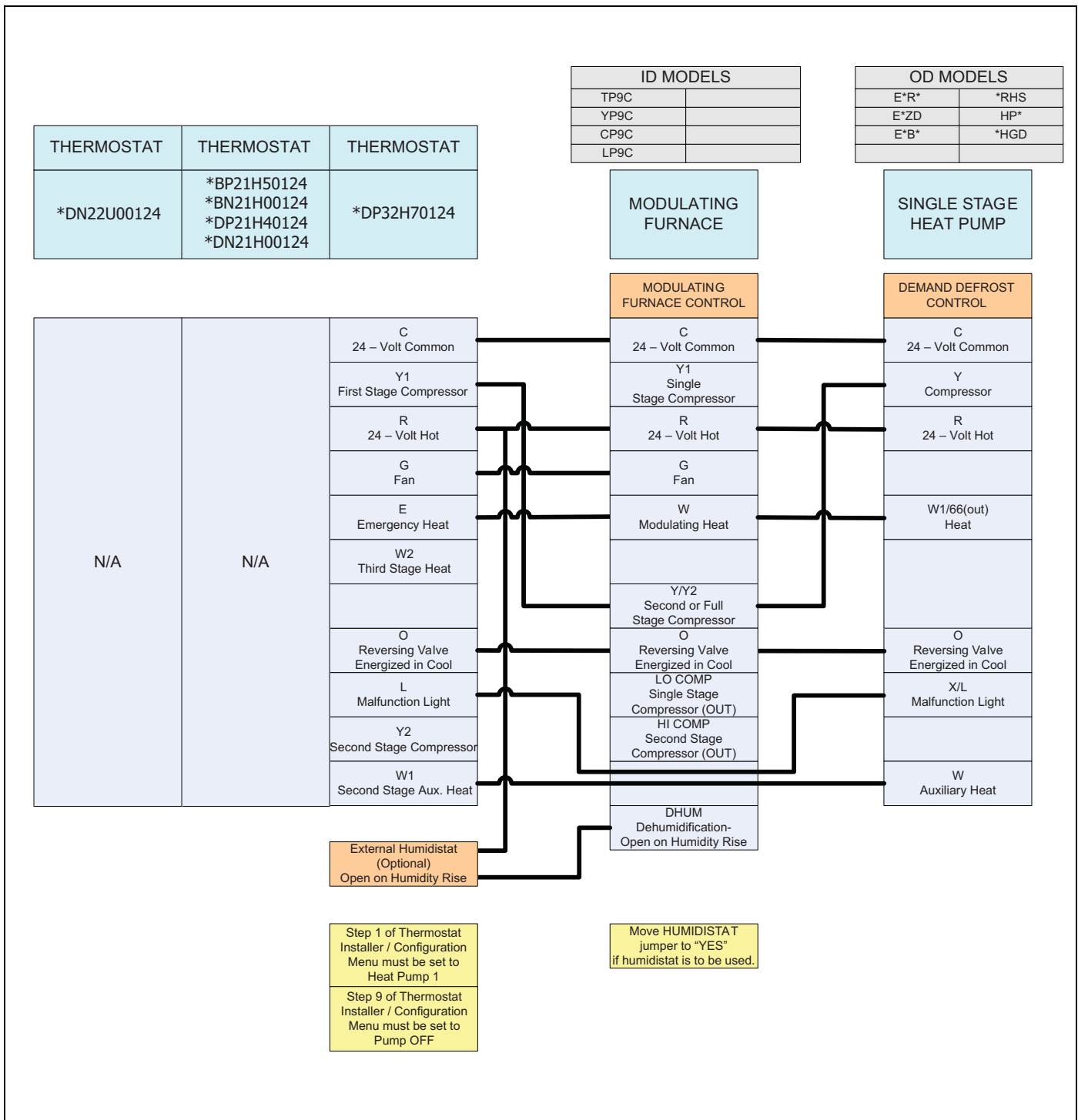

FIGURE 25: Thermostat Chart - Single Stage Heat Pump – Variable Speed Modulating Furnace

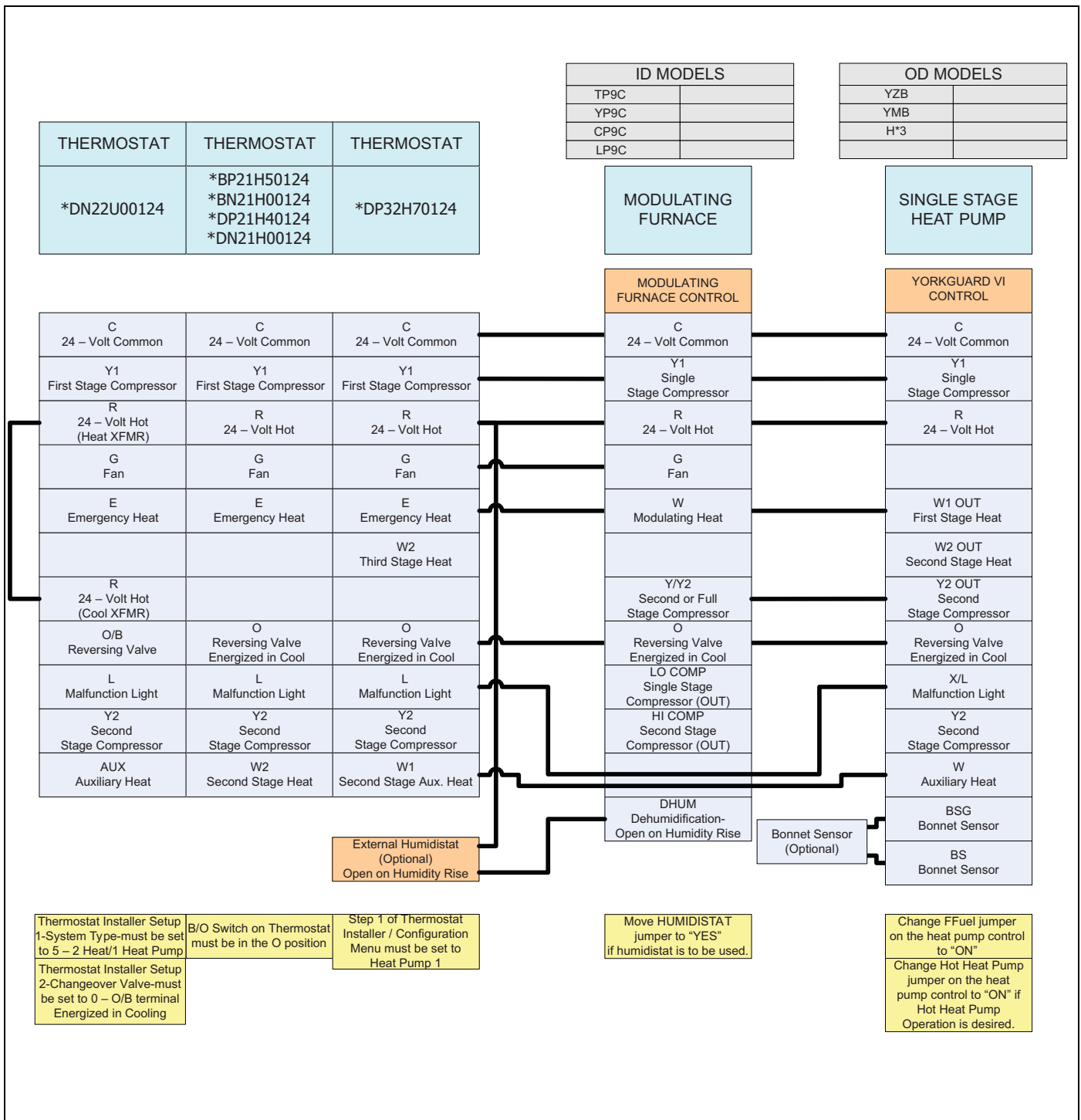

FIGURE 26: Thermostat Chart - Single Stage Heat Pump – Variable Speed Modulating Furnace

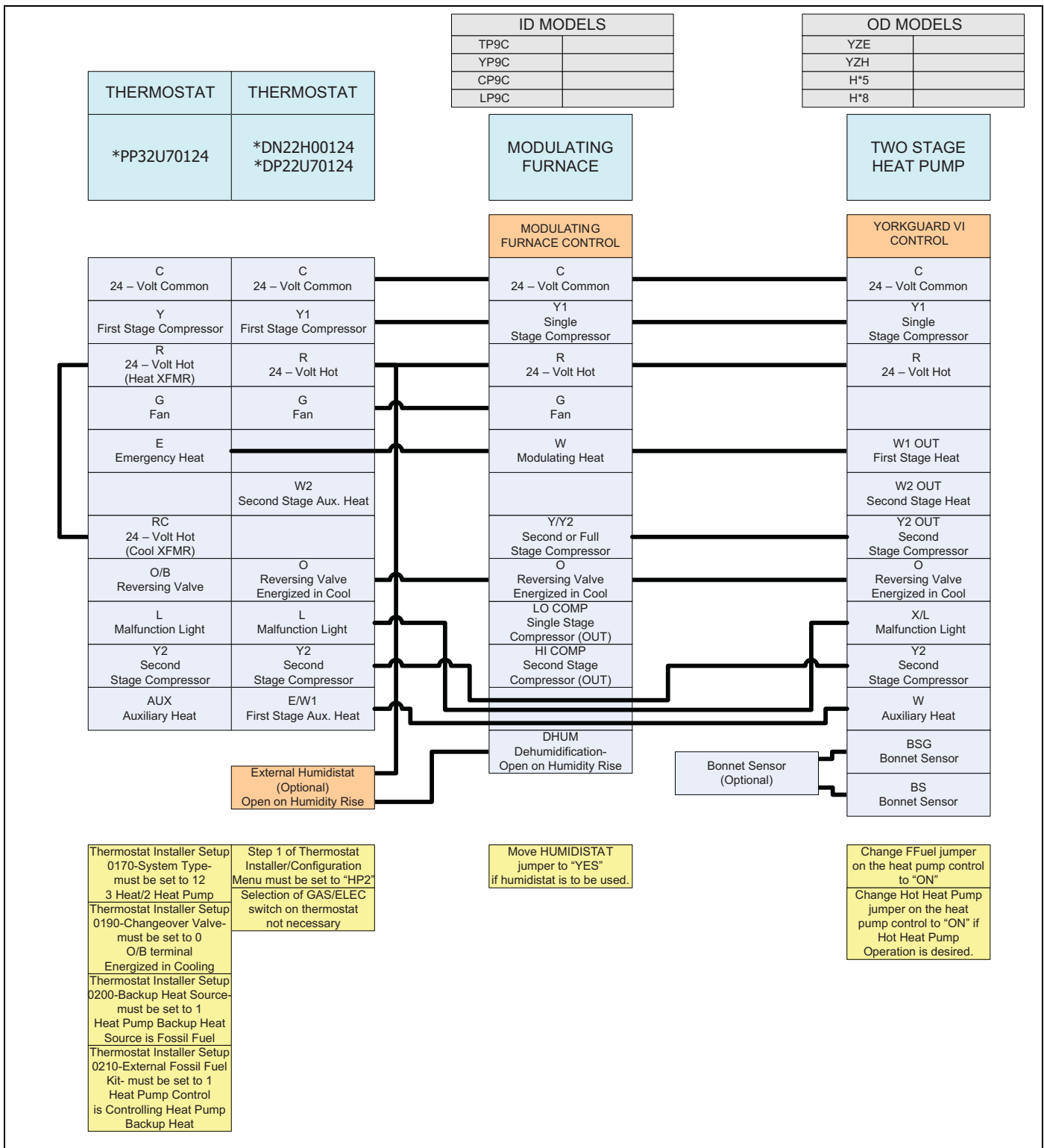

FIGURE 27: Thermostat Chart - Two Stage Heat Pump – Variable Speed Modulating Furnace

ACCESSORY CONNECTIONS

The furnace control will allow power-switching control of various accessories.

ELECTRONIC AIR CLEANER CONNECTION

Two 1/4" (6.4 mm) spade terminals (EAC and NEUTRAL) for electronic air cleaner connections are located on the control board. The terminals provide 115 VAC (1.0 amp maximum) during circulating blower operation.

HUMIDIFIER CONNECTION

Two 1/4" (6.4 mm) spade terminals (HUM and NEUTRAL) for humidifier connections are located on the control board. The terminals provide 115 VAC (1.0 amp maximum) during heating system operation.

A mounting hole is provided on the control panel next to the furnace control board for mounting a humidifier transformer if read.

HUMIDISTAT CONNECTION

For better humidity control during cooling operation, an external humidistat may be used. When using an external humidistat, put the HUMIDISTAT jumper in the YES position. Connect the low voltage wiring as shown in Figures 22-27.

ZONING OPERATION

This furnace may be used in zoning systems, using a separate after-market zoning control. For use in zoned systems, put the ZONE CONTROL jumper on the furnace control board in the "YES" position.

If the Zone jumper is put in the "Yes" position, the heating load logic switches to a special algorithm for multi-zone homes.

1. This algorithm operates at the "low demand" firing rate for 10 minutes and then ramps to high fire within 20 minutes (30 minutes maximum to get to 100% firing rate).
2. The special zoning algorithm does not have the Run 2 function, so the burners will stop firing as soon as there is no call for heating.

HEAT PUMP OPERATION

This furnace may be used in conjunction with a heat pump in dual fuel applications. For heat pump applications, put the HEAT PUMP jumper on the furnace control board in the "YES" position. Connect the low voltage wiring as shown in Figures 25-27, Thermostat Charts. If a two-stage heat pump is to be used, a two-stage thermostat is required.

If the Heat Pump jumper is in the "YES" position, it indicates that there is a heat pump present and the furnace is used as a secondary heat source. In addition, the "YES" Heat Pump jumper allows the system to read the presence of the "O" terminal signal. In heat pump operation, the following special algorithm logic applies:

1. Supplemental Heating - When both a "W" signal and a "Y1" signal are present, the modulating firing rate will operate as normal, except there will be no Run 2 function, so the burners will stop firing as soon as the "W" signal is removed.
2. Defrost Cycle - When both a "W" signal and a "Y2" signal are present, the modulating firing rate will operate at a constant 80% firing rate and there will be no Run 2 function, so the burners will stop firing as soon as the "W" signal is removed.
3. Hot Heat Pump - The "hot" heat pump feature will work when the control is wired to a 2-stage thermostat and a 2-stage heat pump.
4. Hot Heat Pump - The "hot" heat pump feature will not work when the control is wired to a single-stage thermostat and a 2-stage heat pump.

TWINNING

These furnaces are not to be twinned. If more than one furnace is needed in an application, each furnace must have its own complete duct system and its own wall thermostat.

SECTION VI: CONDENSATE PIPING AND FURNACE VENTING CONFIGURATION

CONDENSATE DRAIN LOCATION

As shipped from the factory:

- For all 060 & 080K input furnaces the main drain is plumbed through the casing right-side opening when viewed from the front of the furnace.
- For all 100, 120K input furnaces the main drain is plumbed through the casing left-side opening when viewed from the front of the furnace.

The Figures 29-32 show the condensate drain arrangement for the various possible furnace and vent blower positions.

The condensate hoses must slope downwards at all points.

The condensate water will flow to the drain better if an open tee, or short length of pipe is installed in the drain line.

CAUTION

The furnace condensate pan is self priming and contains an internal trap to prevent flue gas leaking. Do not install an external condensate trap.

When drain hose routing changes are required (shown in Figures 29-32), be sure to cap all un-used openings.

If rerouting hoses - excess length should be cut off so that no sagging loops will collect and hold condensate - which will cause the furnace to not operate.

No hose clamps are needed for connecting the condensate pan.

IMPORTANT

The furnace, evaporator coil, and humidifier drains may be combined and drained together. The evaporator coil drain may have an external, field-supplied trap prior to the furnace drain connection to prevent conditioned air leakage. All drain connections (furnace, evaporator coil, or humidifier) must be terminated into an open or vented drain as close to the respective equipment as possible. Regular maintenance is required on condensate drainage system.

IMPORTANT

Condensate must be disposed of properly. Follow local plumbing or wastewater codes. The drain line must maintain a 1/4" per foot (21 mm/m) downward slope to the drain.

IMPORTANT

If an external vent tee is being installed, then it must have its own condensate trap before it is disposed into an open or vented drain. This is not to be considered as a second trap as referenced elsewhere in this document.

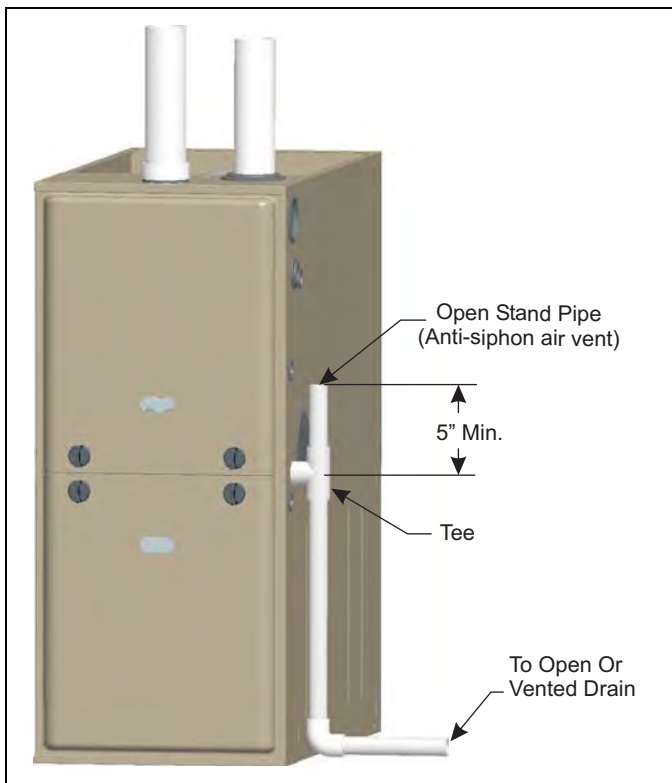

FIGURE 28: Typical Condensate Drain, Vertical Installation

The condensate will flow to the drain better if an open stand pipe is installed in the drain line. See Figure 28.

If evaporator coil or humidifier drains are combined with the furnace drain, then the open stand pipe could be raised higher, above the 5" minimum.

Do not drain other devices (humidifier, evaporator coil, etc.) into the top opening of the vent stand pipe. Instead, install a second tee in the vented drain tube below the furnace drain tee and route additional drainage through the new tee.

NOTICE

A loop has been added to the pressure switch vacuum hose. However, ensure that all pressure switch hoses are routed such that they prevent any condensate from entering the pressure switch.

CAUTION

It is possible for condensation to form inside the combustion air (intake) pipe in the summer months if significant length of combustion air pipe passes through conditioned space. This problem can be averted by installing the supplied vent drain and drain hose located in the loose parts bag. The intake drain hose is to be installed by connecting it to the inlet pipe coupling and to the collector box as shown in Figures 29, 31, and 32. The drain hose must not sag or droop after it is installed. If glue is used when connecting the intake pipe to the intake coupling, the drain opening in the vent drain must not be plugged. If the intake drain is used, the bird screen **cannot** be installed. This is only approved for upflow and horizontal applications when the intake pipe is located on the top of the furnace. This is true for all long horizontal venting in any furnace configuration. This will keep condensate from entering the furnace.

CONDENSATE DRAIN TERMINATION

A condensate sump pump **MUST** be used if required by local codes, or if no indoor floor drain is available. The condensate sump pump must be approved for use with acidic condensate.

WARNING

DO NOT terminate the condensate drain in a chimney, or where the drain line may freeze. If the drain line will be exposed to temperatures below freezing, adequate measures must be taken to prevent the drain line from freezing. Failure to provide proper protection from freezing can result in improper operation or damage to the equipment and possible property damage. When exposed to temperatures below freezing, use of a 3 to 6 watt per foot at 115 VAC, 40°F (4.4°C) self-regulating, shielded and waterproof heat tape is recommended on the drain line outside the furnace.

DO NOT trap the drain line at any location. The furnace has a condensate drain trap built into the drain pan.

WARNING

Liquid anti-freeze will cause damage to internal plastic parts of this furnace. **DO NOT** attempt to winterize the furnace using liquid anti-freeze.

When drain hose routing changes are required, be sure to cap all un-used openings. If rerouting hoses - excess length should be cut off so that no sagging loops will collect and hold condensate, which will cause the furnace to not operate.

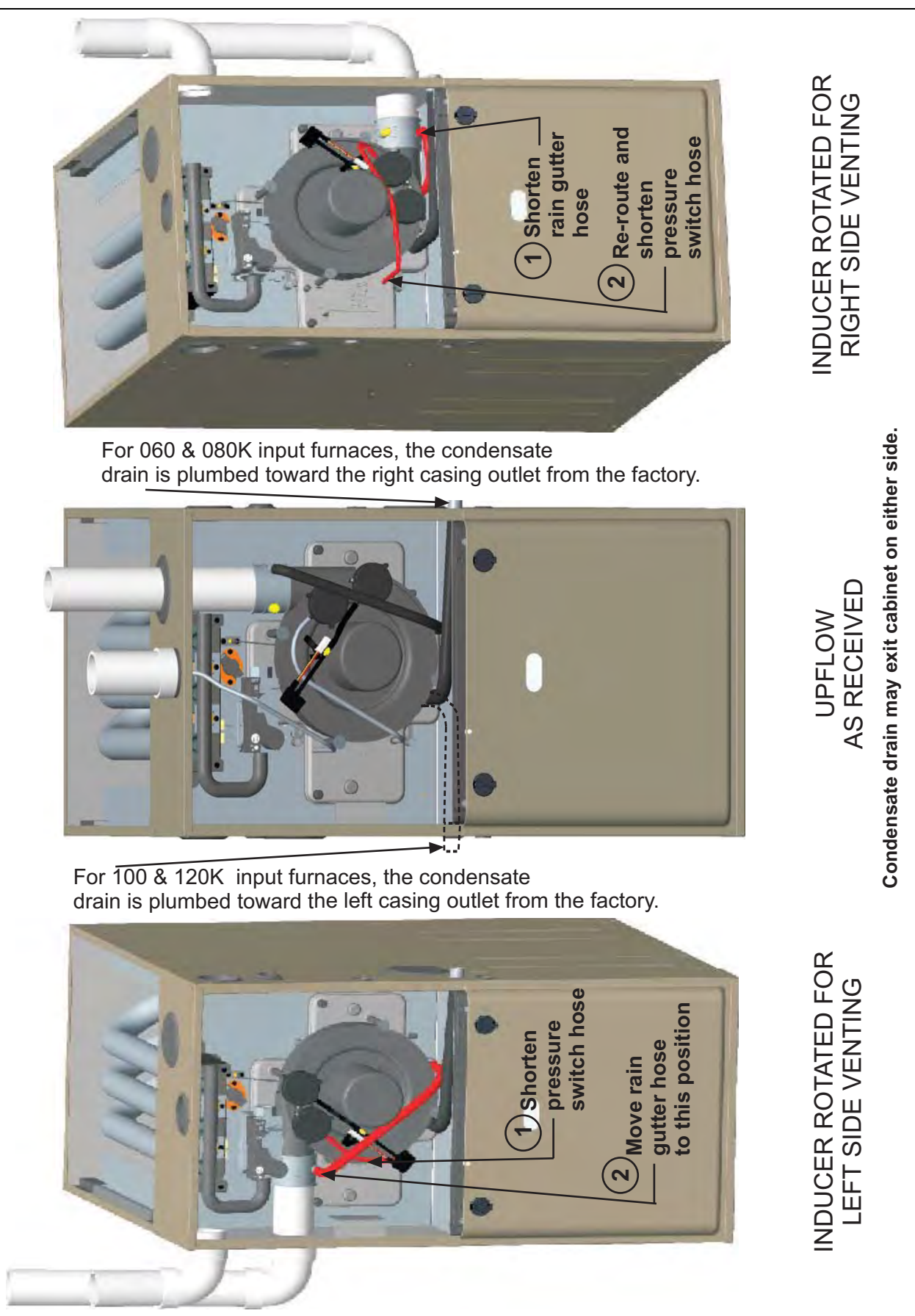

For 060 & 080K input furnaces, the condensate drain is plumbed toward the right casing outlet from the factory.

For 100 & 120K input furnaces, the condensate drain is plumbed toward the left casing outlet from the factory.

INDUCER ROTATED FOR
RIGHT SIDE VENTING

UPFLOW
AS RECEIVED

INDUCER ROTATED FOR
LEFT SIDE VENTING

Condensate drain may exit cabinet on either side.

FIGURE 29: Upflow Configuration

When drain hose routing changes are required, be sure to cap all un-used openings. If rerouting hoses - excess length should be cut off so that no sagging loops will collect and hold condensate, which will cause the furnace to not operate.

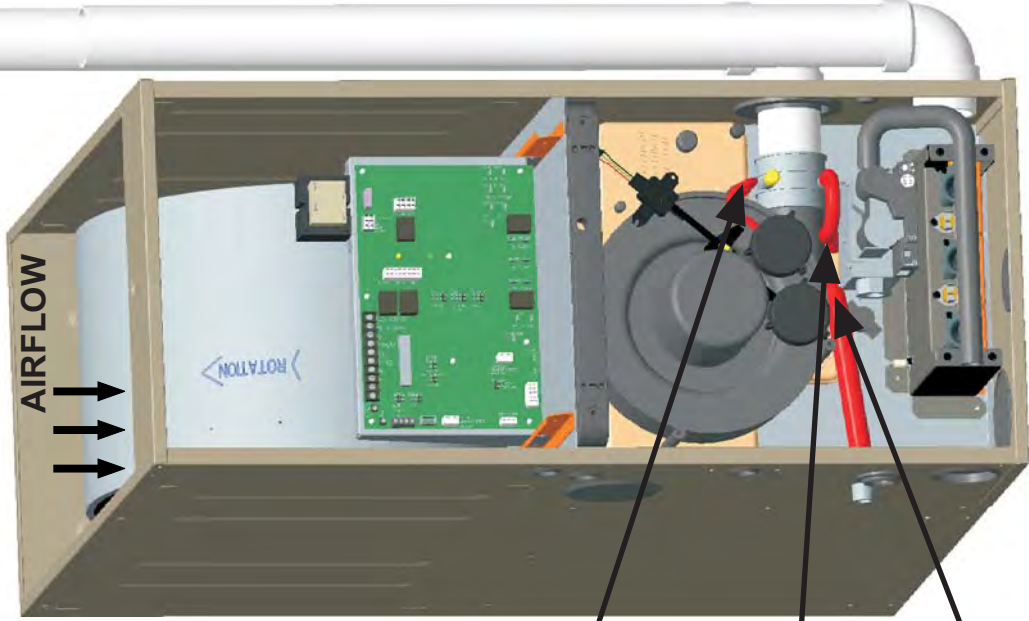

DOWNFLOW - INDUCER ROTATED FOR RIGHT SIDE VENTING

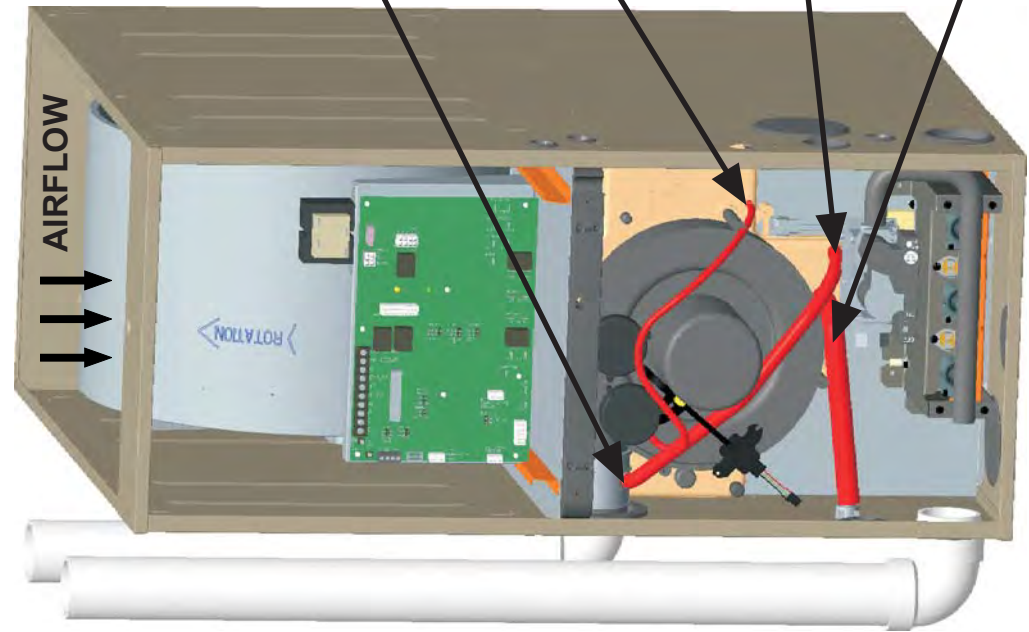

DOWNFLOW - INDUCER ROTATED FOR LEFT SIDE VENTING

- ① Move rain gutter hose to this position
- ② Move pressure switch hose to this position.
NOTE: May require the longer hose that is provided with wider cabinets
- ③ Move rain gutter hose to this position
- ④ Move condensate drain hose to this position (May exit either side of the cabinet)

FIGURE 30: Downflow Configuration

When drain hose routing changes are required, be sure to cap all un-used openings. If rerouting hoses - excess length should be cut off so that no sagging loops will collect and hold condensate, which will cause the furnace to not operate.

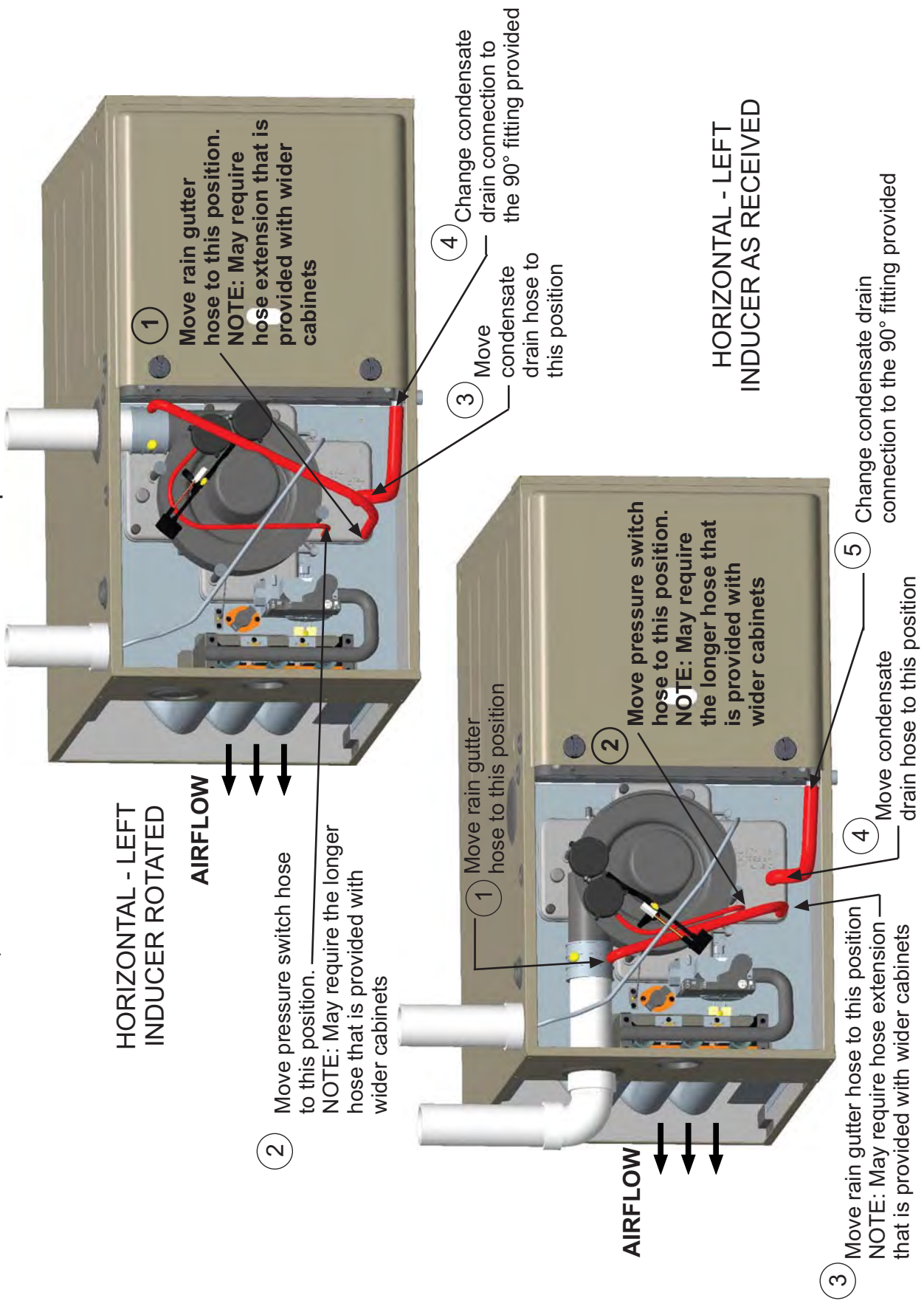

FIGURE 31: Horizontal Left Configuration

When drain hose routing changes are required, be sure to cap all un-used openings. If rerouting hoses - excess length should be cut off so that no sagging loops will collect and hold condensate, which will cause the furnace to not operate.

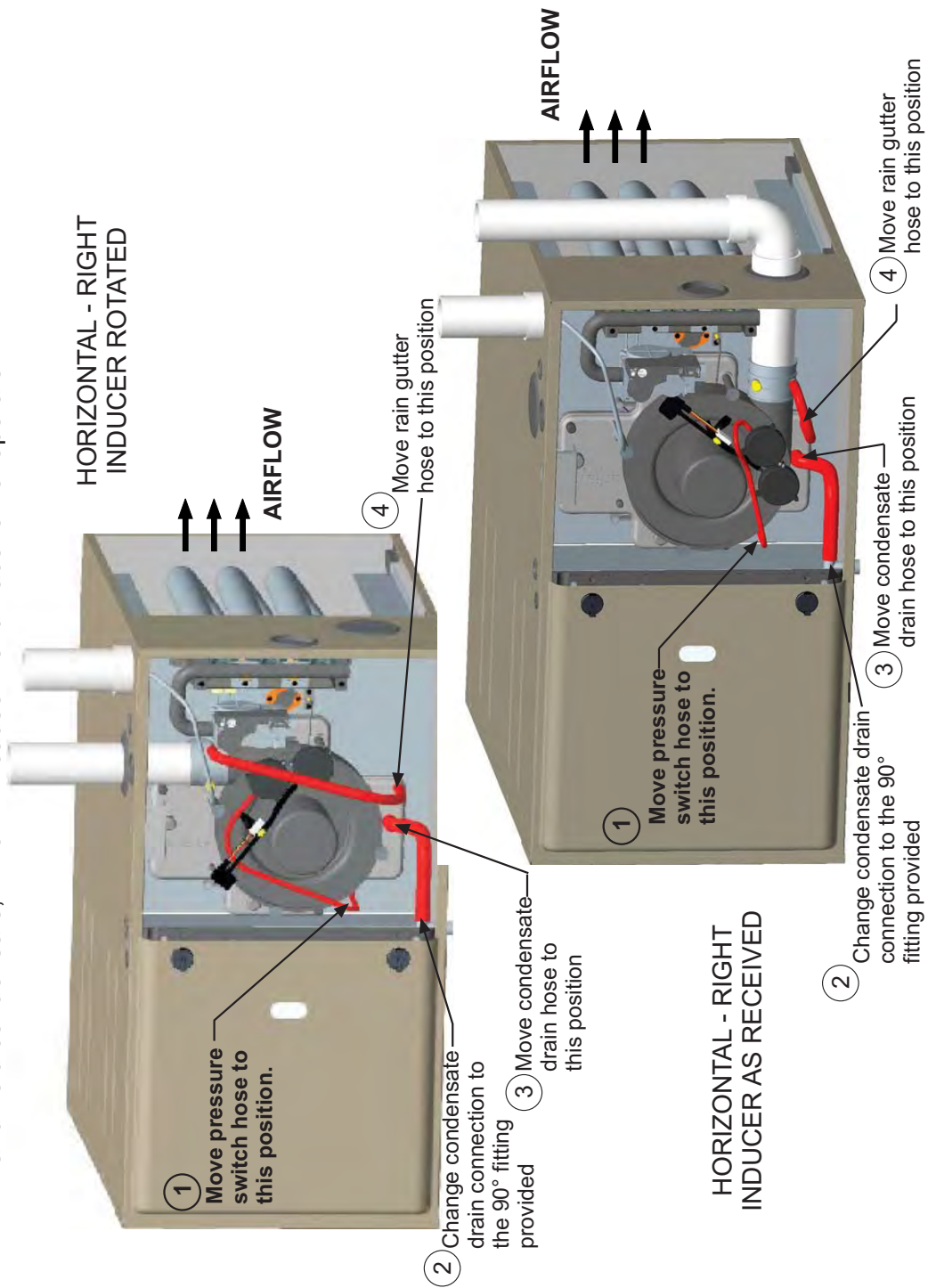

FIGURE 32: Horizontal Right Configuration

SECTION VII: COMBUSTION AIR AND VENT SYSTEM

COMBUSTION AIR AND VENT SAFETY

This Category IV, dual certified direct vent furnace is designed for residential application. It may be installed without modification to the condensate system in a basement, garage, equipment room, alcove, attic or any other indoor location where all required clearance to combustibles and other restrictions are met. The combustion air and the venting system must be installed in accordance with Section 5.3, Air for Combustion and Ventilation, of the National Fuel Gas Code Z223.1/NFPA 54 (latest edition), or Sections 7.2, 7.3 or 7.4 of CSA B149.1, National Gas and Propane Codes (latest edition) or applicable provisions of the local building code and these instructions.

IMPORTANT

The "VENT SYSTEM" must be installed as specified in these instructions for Residential and non-HUD Modular Homes. The direct vent system is the only configuration that can be installed in a non-HUD Modular Home.

WARNING

*This furnace may not be common vented with any other appliance, since it requires separate, properly sized air intake and vent lines. The furnace shall not be connected to any type of B, BW or L vent or vent connector, and not connected to any portion of a factory-built or masonry chimney.
The furnace shall not be connected to a chimney flue serving a separate appliance designed to burn solid fuel.*

CAUTION

*When combustion air pipe is installed above a suspended ceiling or when it passes through a warm and humid space, the pipe must be insulated with 1/2" Armaflex or other heat resistant type insulation if two feet or more of pipe is exposed.
Vent piping must be insulated if it will be subjected to freezing temperatures such as routing through unheated areas or through an unused chimney.*

COMBUSTION AIR/VENT PIPE SIZING

The size of pipe required will be determined by the furnace model, the total length of pipe required and the number of elbows required.

Table 7 lists the maximum equivalent length of pipe allowed for each model of furnace. The equivalent length of pipe for each elbow installed is listed in Table 9. The equivalent length of the vent system is the total length of straight pipe PLUS the equivalent length of all of the elbows.

The following rules must also be followed:

1. Drain, waste, and vent (DWV) elbows with a long radius (sweep) are recommended. Standard DWV elbows may be used, but since they have a longer equivalent length, they will reduce the total length of pipe that will be allowed. Short radius (plumbing or pressure) elbows are not allowed for venting. The standard dimensions of the acceptable elbows are shown in Figure 33.
2. The maximum equivalent length listed in Table 7 is for the vent piping and the air intake piping separately. For example, if the table allows 65 equivalent feet for a particular model, then the vent can have 65 equivalent feet of pipe, AND the combustion air intake can have another 65 equivalent feet of pipe.
3. Three vent terminal elbows (two for the vent and one for the combustion air intake) are already accounted for and need not be included in the equivalent length calculation.
4. All combustion air and vent pipe must conform to American National Standards Institute (ANSI) and American Society for Testing and Materials (ASTM) standards D1785 (Schedule 40 PVC), D2665 (PVC-DWV), F891 (PVC-DWV Cellular Core), D2261 (ABS-DWV) or F628 (Schedule 40 ABS). Pipe cement and primer must conform to ASTM Standard D2546 (PVC) or D2235 (ABS). If ABS pipe is to be used, any joint where ABS pipe is joined to PVC pipe must be glued with cement that is approved for use with BOTH materials. Metallic materials must not be used for venting or air intake.
5. If a flexible connector is used in the vent system, it must be made of a material that is resistant to acidic exposure and to at least 225°F temperature. Flexible connectors are also allowed in the combustion air pipe.
6. All models are supplied with 2" (5.1 cm) vent connections. When the pipe must be increased to 3" (7.6 cm) diameter, the transition from 2" to 3" must be done as close to the furnace as possible. The 2" to 3" increase should be installed in the vertical position as to not create an area that will pool water.
7. In Canada, vents shall be certified to ULC S636, Standard for Type BH Gas Venting Systems.
8. In Canada, the first three feet (914 mm) of the vent must be readily accessible for inspection.
9. For single pipe systems it is recommended to install the combustion air coupling provided and install approximately 18" of PVC pipe on the furnace.
10. Minimum vent length is five feet for all models.

Table 7: Maximum Equivalent Pipe Length

Elevation Sea level - 2000			Elevation 6001 - 7000		
Model Input (BTUH)	Pipe Size (in)	Max. equivalent Length (ft)	Model Input (BTUH)	Pipe Size (in)	Max. equivalent Length (ft)
60,000	2	65	60,000	2	40
60,000	3	90	60,000	3	65
60,000	4	150	60,000	4	130
80,000	2	65	80,000	2	30
80,000	3	90	80,000	3	65
80,000	4	150	80,000	4	130
100,000	2	30	100,000	2	5
100,000	3	90	100,000	3	65
100,000	4	150	100,000	4	130
120,000	3	90	120,000	3	65
120,000	4	150	120,000	4	130
Elevation 2001 - 4000			Elevation 7001-8000		
Model Input (BTUH)	Pipe Size (in)	Max. equivalent Length (ft)	Model Input (BTUH)	Pipe Size (in)	Max. equivalent Length (ft)
60,000	2	55	60,000	2	35
60,000	3	80	60,000	3	60
60,000	4	145	60,000	4	125
80,000	2	55	80,000	2	25
80,000	3	80	80,000	3	60
80,000	4	145	80,000	4	125
100,000	2	20	100,000	2	NA
100,000	3	80	100,000	3	60
100,000	4	145	100,000	4	125
120,000	3	80	120,000	3	60
120,000	4	145	120,000	4	125
Elevation 4001 - 5000			Elevation 8001-9000		
Model Input (BTUH)	Pipe Size (in)	Max. equivalent Length (ft)	Model Input (BTUH)	Pipe Size (in)	Max. equivalent Length (ft)
60,000	2	50	60,000	2	30
60,000	3	75	60,000	3	55
60,000	4	140	60,000	4	120
80,000	2	50	80,000	2	20
80,000	3	75	80,000	3	55
80,000	4	140	80,000	4	120
100,000	2	15	100,000	2	NA
100,000	3	75	100,000	3	55
100,000	4	140	100,000	4	120
120,000	3	75	120,000	3	55
120,000	4	140	120,000	4	120
Elevation 5001 - 6000			Elevation 9001-10000		
Model Input (BTUH)	Pipe Size (in)	Max. equivalent Length (ft)	Model Input (BTUH)	Pipe Size (in)	Max. equivalent Length (ft)
60,000	2	45	60,000	2	25
60,000	3	70	60,000	3	50
60,000	4	135	60,000	4	115
80,000	2	35	80,000	2	15
80,000	3	70	80,000	3	50
80,000	4	135	80,000	4	115
100,000	2	10	100,000	2	NA
100,000	3	70	100,000	3	50
100,000	4	135	100,000	4	115
120,000	3	70	120,000	3	50
120,000	4	135	120,000	4	115

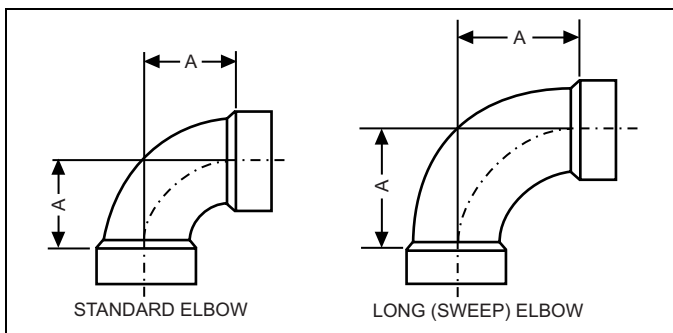

FIGURE 33: Dimensions

TABLE 8: Elbow Dimensions

Elbow	"A" Dimension (Illustrated in Figure 33)
2" Standard	2-5/16"
3" Standard	3-1/16"
2" Sweep	3-1/4"
3" Sweep	4-1/16"

Dimensions are those required in Standard ASTM D-3311.

TABLE 9: Equivalent Length of Fittings

Fitting	Equivalent Length
2" 90° sweep elbow	5 feet of 2" pipe
2" 45° sweep elbow	2-1/2 feet of 2" pipe
2" 90° standard elbow	7 feet of 2" pipe
2" 45° standard elbow	3-1/2 feet of 2" pipe
3" 90° sweep elbow	5 feet of 3" pipe
3" 45° sweep elbow	2-1/2 feet of 3" pipe
3" 90° standard elbow	7 feet of 3" pipe
3" 45° standard elbow	3-1/2 feet of 3" pipe
4" 90° elbow (sweep or standard)	5 feet of 4" pipe
4" 45° elbow (sweep or standard)	2-1/2 feet of 4" pipe
2" corrugated connector	10 feet of 2" pipe
3" corrugated connector	10 feet of 3" pipe
4" corrugated connector	10 feet of 4" pipe

Example:

An 80,000 BTUH furnace requires 32 feet of pipe and five 90° elbows. Using 2" pipe and standard elbows, the total equivalent length will be:

$$\begin{array}{r}
 32 \text{ feet of 2" pipe} = 32 \text{ equivalent feet} \\
 5 - 90^\circ \text{ standard 2" elbows} = (5 \times 7) = 35 \text{ equivalent feet} \\
 \hline
 \text{Total} = 67 \text{ equivalent feet of 2" pipe}
 \end{array}$$

This exceeds the 65 foot maximum equivalent length of 2" pipe allowed for that model and is thus not acceptable.

By using sweep elbows, the total equivalent length will be:

$$\begin{array}{r}
 32 \text{ feet of 2" pipe} = 32 \text{ equivalent feet} \\
 5 - 90^\circ \text{ sweep 2" elbows} = (5 \times 5) = 25 \text{ equivalent feet} \\
 \hline
 \text{Total} = 57 \text{ equivalent feet of 2" pipe}
 \end{array}$$

This is less than the 65 foot maximum equivalent length of 2" pipe allowed for that model and is thus acceptable.

Alternatively, using 3" pipe and standard elbows, the total equivalent length will be:

$$\begin{array}{r}
 32 \text{ feet of 3" pipe} = 32 \text{ equivalent feet} \\
 5 - 90^\circ \text{ standard 3" elbows} = (5 \times 7) = 35 \text{ equivalent feet} \\
 \hline
 \text{Total} = 67 \text{ equivalent feet of 3" pipe}
 \end{array}$$

This is less than the 90 foot maximum equivalent length of 3" pipe allowed for that model and is thus acceptable.

TABLE 10: Combustion Air Intake and Vent Connection Size at Furnace (All Models)

FURNACE VENT CONNECTION SIZES	
Furnace Input	All
Intake Pipe Size	2" (5.1 cm)
Vent Pipe Size	2" (5.1 cm)

IMPORTANT

Furnace vent pipe connections are sized for 2" (51 mm) pipe. Any pipe size change must be made outside the furnace casing in a vertical pipe section to allow proper drainage of condensate. An offset using two 45° (degree) elbows will be required for plenum clearance when the vent is increased to 3" (76 mm).

IMPORTANT

Accessory concentric vent / intake termination kits 1CT0302 and 1CT0303, and for Canadian applications ICT0302-636 and ICT0303-636 are available and approved for use with these furnaces. Horizontal sidewall vent terminations kits 1HT0901 & 1HT0902 are also approved for use with these furnaces.

COMBUSTION AIR AND VENT PIPING ASSEMBLY

The final assembly procedure for the combustion air and vent piping is as follows:

1. Cut piping to the proper length beginning at the furnace.
2. Deburr the piping inside and outside.
3. Chamfer (bevel) the outer edges of the piping.
4. Dry-fit the vent piping assembly from the furnace to the outside termination checking for proper fit support and slope.
5. Dry-fit the combustion air piping assembly checking for proper fit, support and slope on the following systems:
 - a. Sealed combustion air systems from the furnace to the outside termination.
 - b. Ventilated combustion air systems from the furnace to the attic or crawl space termination.

CAUTION

Solvent cements are flammable and must be used in well-ventilated areas only. Keep them away from heat, sparks and open flames. Do not breathe vapors and avoid contact with skin and eyes.

6. Disassemble the combustion air and vent piping, apply cement primer and the cement per the manufactures instructions. Primer and cement must conform to ASTM D2564 for PVC, or ASTM D2235 for ABS piping.
7. All joints must provide a permanent airtight and watertight seal.
8. Install the combustion air and vent piping such that it has a 1/4" per foot (21 mm/m) grade so that condensate will flow back towards the furnace. Piping should be supported with pipe hangers to prevent sagging.
9. Seal around the openings where the combustion air and / or vent piping pass through the roof or sidewalls.

COMBUSTION AIR / VENTING

IMPORTANT

The vent must be installed with the required clearances, and must comply with local codes and requirements.

VENT CLEARANCES

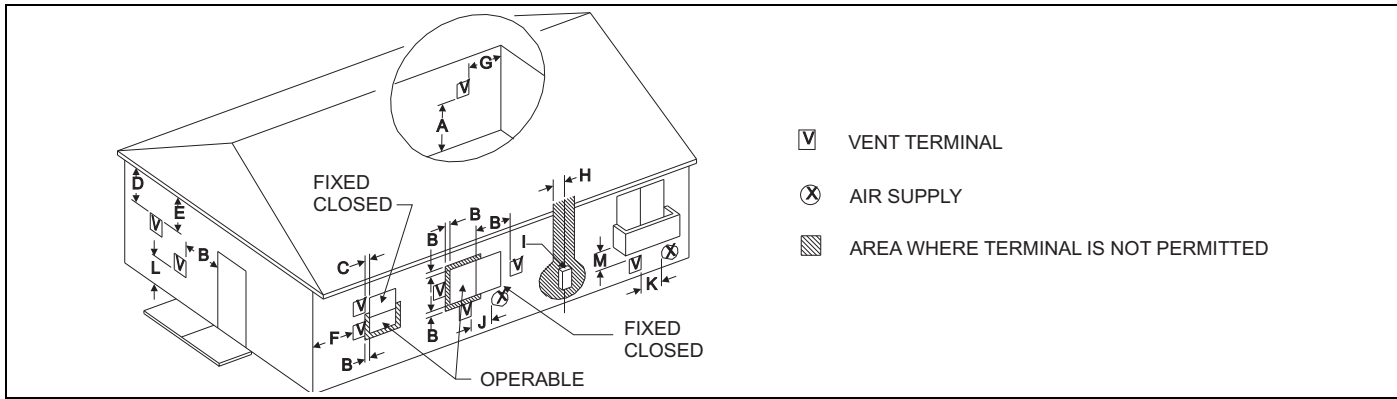

FIGURE 34: Home Layout

Direct Vent Terminal Clearances	Canadian Installations ^{1,3}	US Installation ^{2,3}
A. Clearance above grade, veranda, porch, deck, or balcony	12" (30.5 cm)	12" (30.5 cm)
B. Clearance to window or door that may be opened	12" (30.5 cm) for models ≤100,000 BTUH (30 kW), 36" (91.4 cm) for models >100,000 BTUH (30 kW).	Two-pipe (direct vent) applications: 12" (30.5 cm)†† Single-pipe applications: 4 feet (1.2 m).
C. Clearance to permanently closed window	12" (30.5 cm)	12" (30.5 cm)
D. Vertical clearance to ventilated soffit located above the terminal within a horizontal distance of 2 feet (61 cm) from the center line of the terminal	12" (30.5 cm) or in accordance with local installation codes and the requirements of the gas supplier.	12" (30.5 cm) or in accordance with local installation codes and the requirements of the gas supplier.
E. Clearance to unventilated soffit	12" (30.5 cm) or in accordance with local installation codes and the requirements of the gas supplier.	12" (30.5 cm) or in accordance with local installation codes and the requirements of the gas supplier.
F. Clearance to outside corner	12" (30.5 cm) or in accordance with local installation codes and the requirements of the gas supplier.	12" (30.5 cm) or in accordance with local installation codes and the requirements of the gas supplier.
G. Clearance to inside corner	3 feet (91.4 cm)	3 feet (91.4 cm)
H. Clearance to each side of center line extended above meter/regulator assembly	Above a meter/regulator assembly within 3 feet (91.4 cm) horizontally of the vertical center-line of the regulator vent outlet to a maximum vertical distance of 15 feet (4.5 m) above the meter/regulator assembly.	Above a meter/regulator assembly within 3 feet (91 cm) horizontally of the vertical center-line of the regulator vent outlet to a maximum vertical distance of 15 feet (4.5 m) above the meter/regulator assembly.
I. Clearance to service regulator vent outlet	3 feet (91.4 cm)	3 feet (91.4 cm) or in accordance with local installation codes and the requirements of the gas supplier.
J. Clearance to non-mechanical air supply inlet to building or the combustion air inlet to any other appliance	12" (30.5 cm) for models ≤100,000 BTUH (30 kW), 36" (91 cm) for models >100,000 BTUH (30 kW).	Two-pipe (direct vent) applications: 12" (30.5 cm) Single-pipe applications: 4 feet (1.2 m).
K. Clearance to a mechanical supply inlet	6 feet (1.83 m)	3 feet (91.4 cm) above if within 10 feet (3 m) horizontally.
L. Clearance above paved sidewalk or paved driveway located on public property	7 feet (2.13 m)†	7 feet (2.13 m) or in accordance with local installation codes and the requirements of the gas supplier.
M. Clearance under veranda, porch, deck, or balcony	12" (30.5 cm)‡	12" (30.5 cm) or in accordance with local installation codes and the requirements of the gas supplier.

- 1. In accordance with the current CSA B149.1-00, Natural Gas and Propane Installation Code.
- 2. In accordance with the current ANSI Z223.1 / NFPA 54, National Gas Code.
- 3. In accordance with the current ANSI Z21.47 * CSA 2.3 American National Standard.

† A vent shall not terminate directly above a sidewalk or paved driveway that is located between two single family dwellings and serves both dwellings.

†† 12" (30.5 cm) up from the bottom edge of the structure for Two-pipe (direct vent) applications per ANSI Z223.1 / NFPA 54, National Gas Code.

‡ Permitted only if veranda, porch, deck, or balcony is fully open on a minimum of two sides beneath the floor and the distance between the top of the vent termination and the underside of the veranda, porch, or deck is greater than 12" (30.5 cm) as specified in CSA B149.1-00.

A vent shall not terminate less than 12" (30.5 cm) above a grade level.

Any fresh air or make up inlet for dryer or furnace area is considered to be forced air inlet.

Avoid areas where condensate drippage may cause problems such as above planters, patios, or adjacent to windows where steam may cause fogging.

A terminus of a vent shall be fitted with a cap in accordance with the vent manufacturer's installation instructions, or in accordance with the installation instructions for a special venting system.

Responsibility for the provision of proper adequate venting and air supply for application shall rest with the installer.

Vent shall extend high enough above building, or a neighboring obstruction, so that wind from any direction will not create a positive pressure in the vicinity of the vent.

IMPORTANT

Consideration must be given for degradation of building materials by flue gases. Sidewall termination may require sealing or shielding of building surfaces with a corrosion resistant material to protect against combustion product corrosion. Consideration must be given to wind direction in order to prevent flue products and/or condensate from being blown against the building surfaces. If a metal shield is used it must be a stainless steel material at a minimum dimension of 20 inches (51 cm). It is recommended that a retaining type collar be used that is attached to the building surface to prevent movement of the vent pipe.

VENT SYSTEM

This furnace is certified to be installed with one of two possible vent configurations.

1. Horizontal vent system. This vent system can be installed completely horizontal or combinations of horizontal, vertical, or offset using elbows.
2. Vertical vent system. This vent system can be installed completely vertical or a combination of horizontal, vertical, or offset using elbows.

VENT APPLICATIONS AND TERMINATION

When selecting the location for a horizontal combustion air / vent termination, the following should be considered:

1. Observe all clearances listed in vent clearances in these instructions.
2. Termination should be positioned where vent vapors will not damage plants or shrubs or air conditioning equipment.
3. Termination should be located where it will not be affected by wind gusts, light snow, airborne leaves or allow recirculation of flue gases.
4. Termination should be located where it will not be damaged or exposed to flying stones, balls, etc.
5. Termination should be positioned where vent vapors are not objectionable.
6. Horizontal portions of the vent system must slope upwards and be supported to prevent sagging.
7. Direct vent systems must be installed so the vent and the combustion air pipes terminate in the same atmospheric zone. Refer to Figures 36 or 37.

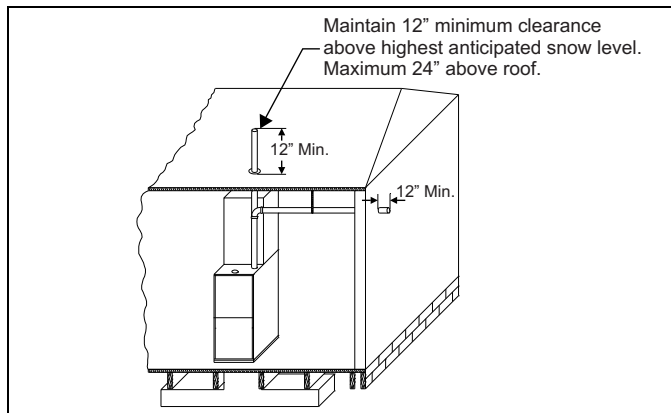

FIGURE 35: Termination Configuration - 1 Pipe

WARNING

Condensation in Intake Pipe

Installations where the furnace and intake pipe are to be located in a conditioned space and in a region that may have hot, humid weather extending several consecutive days will have condensate form in the intake pipe. Use of the supplied intake drain will ensure that any condensate will be safely diverted away from the internal components of the furnace. Proper venting installation (of both intake and exhaust) and sealing any equipment air leaks that might contact the intake pipe will help reduce condensation.

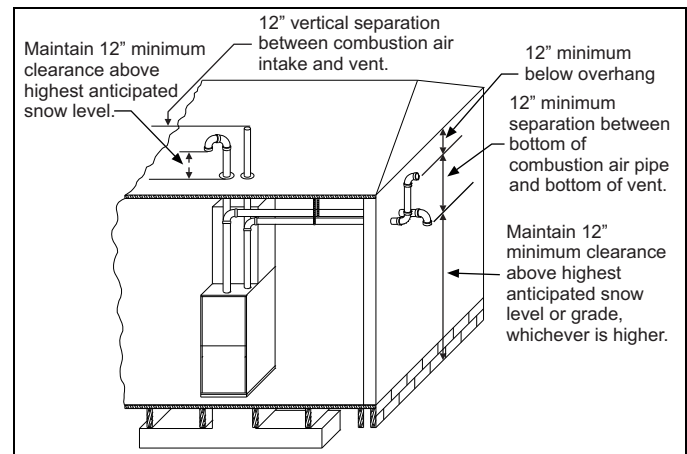

FIGURE 36: Termination Configuration - 2 Pipe

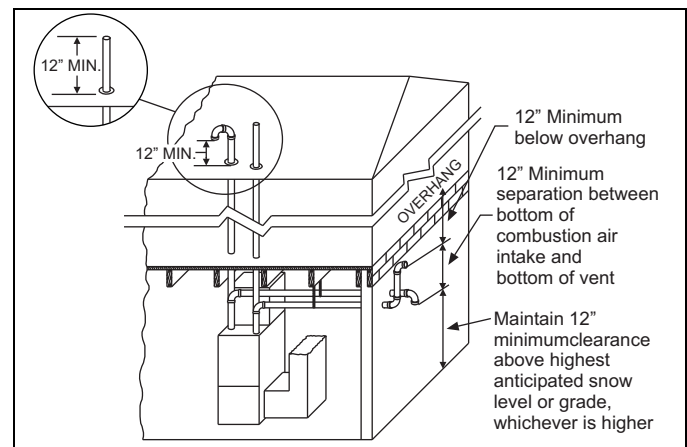

FIGURE 37: Termination Configuration - 2 Pipe Basement

VENTING MULTIPLE UNITS

Multiple units can be installed in a space or structure as either a single pipe configuration or a two-pipe configuration.

The combustion air side of the single pipe configuration shown in Figure 42 is referred to in these instructions as ambient combustion air supply. Follow the instructions for ambient combustion air installations, paying particular attention to the section on air source from inside the building. The vent for a single pipe system must be installed as specified in the venting section of these instructions with both vents terminating as shown in Figure 35. Each furnace must have a separate vent pipe. Under NO circumstances can the two vent pipes be tied together.

The combustion air side of the two-pipe configuration shown in Figures 36 and 37 can be installed so the combustion air pipe terminates as described in outdoor combustion air or ventilated combustion air sections in these instructions. Follow the instructions for outdoor combustion air or ventilated combustion air and the instructions for installing the vent system with the vent terminating as shown in Figure 38 or 39. The two-pipe system must have a separate combustion air pipe and a separate vent pipe for each furnace. Under NO circumstances can the two combustion air or vent pipes be tied together. The combustion air and vent pipes must terminate in the same atmospheric zone.

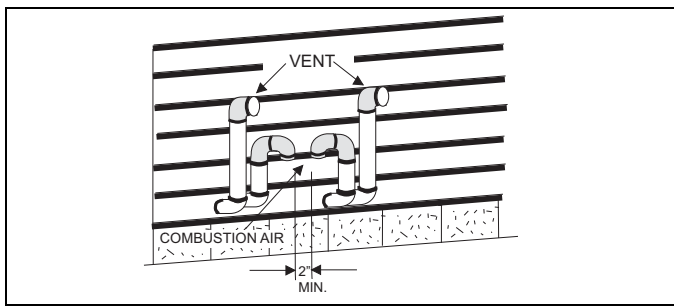

FIGURE 38: Double Horizontal Combustion Air Intake and Vent Termination

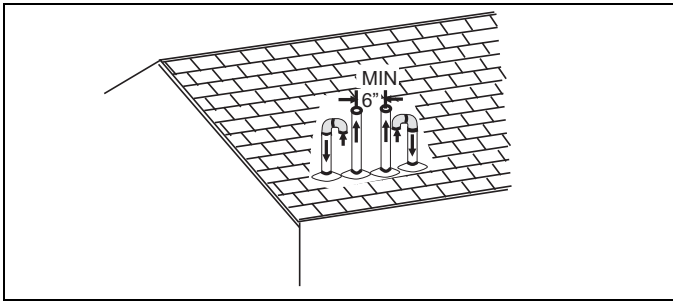

FIGURE 39: Double Vertical Combustion Air Intake and Vent Termination

DOWNWARD VENTING

In some applications, it may be necessary to run the vent pipe and air intake downwards. If this is to be done, the following rules must be followed.

- A condensate trap hose must be connected to both the air intake pipe and the vent pipe at the lowest part of the horizontal run.
- The condensate drain trap must have a trap of a minimum of six inches.
- The total vertical downward distance must not exceed sixteen feet.
- The condensate drain hose must be connected to a condensate drain pump, an open or vented drain or into the condensate drain line from the furnace.
- The condensate drain lines must not pass through unconditioned spaces where the temperature may fall below freezing.
- The condensate drain line must be primed at the initial start-up prior to the start of heating season.

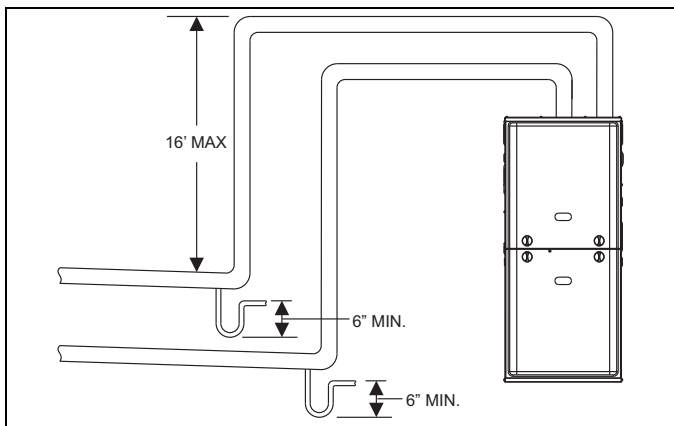

FIGURE 40: Downward Venting

COMBUSTION AIR SUPPLY

All installations must comply with Section 5.3, Air for Combustion and Ventilation of the National Fuel Gas Code, ANSI Z223.1 or Sections 7.2, 7.3 or 7.4 of CAN/CGA B149.1 or B149.2 Installation Code - latest editions.

This furnace is certified to be installed with one of three possible combustion air intake configurations.

1. **OUTDOOR COMBUSTION AIR:** This is a direct vent configuration where the combustion air is supplied through a PVC or ABS pipe that is connected to the PVC coupling attached to the furnace and is terminated in the same atmospheric zone as the vent. This type of installation is approved on all models. Refer to Figure 41.
2. **AMBIENT COMBUSTION AIR:** Combustion air is supplied from the area surrounding the furnace through openings in the furnace casing. The combustion air and the vent pipes are not terminated in the same atmospheric zone. Refer to Figure 35 for vent terminations. Refer to "Ambient Combustion Air Supply" for proper installation. Refer to Figures 42 and 43.
3. **VENTILATED COMBUSTION AIR:** Combustion air is supplied through a PVC or ABS pipe that is connected to the PVC coupling attached to the burner box and is terminated in a ventilated attic or crawl space. The combustion air and the vent pipes are not terminated in the same atmospheric zone. Refer to Figure 44 for attic and crawl space termination. Only the combustion air intake may terminate in the attic. The vent must terminate outside.

Outdoor Combustion Air

Combustion Air Intake/Vent Connections

This installation requires combustion air to be brought in from outdoors. This requires a properly sized pipe (Shown in Figure 41) that will bring air in from the outdoors to the furnace combustion air intake collar on the burner box. The second pipe (Shown in Figure 41) is the furnace vent pipe.

NOTICE

An optional plastic birdscreen is shipped in the loose parts bag with every furnace. This may be installed in the intake collar to prevent any small objects from entering the furnace.

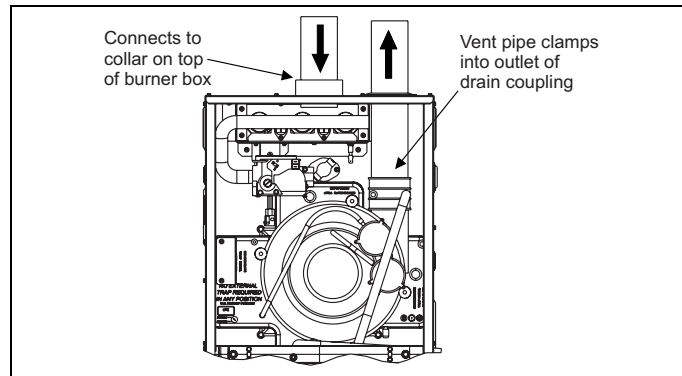

FIGURE 41: Direct Vent Air Intake Connection and Vent Connection

The combustion air intake pipe should be located either through the wall (horizontal or side vent) or through the roof (vertical vent). Care should be taken to locate side vented systems where trees or shrubs will not block or restrict supply air from entering the terminal.

Also, the terminal assembly should be located as far as possible from a swimming pool or a location where swimming pool chemicals might be stored. Be sure the terminal assembly follows the outdoor clearances listed in Section #1 "Outdoor Air Contaminants."

Ambient Combustion Air Supply

This type installation will draw the air required for combustion from within the space surrounding the appliance and from areas or rooms adjacent to the space surrounding the appliance. This may be from within the space in a non-confined location or it may be brought into the furnace area from outdoors through permanent openings or ducts. It is not piped directly into the furnace. A single, properly sized pipe from the furnace vent connector to the outdoors must be provided. It is recommended that the supplied intake coupling and 18" of pipe be attached to the furnace to prevent accidental blockage or combustion air intake.

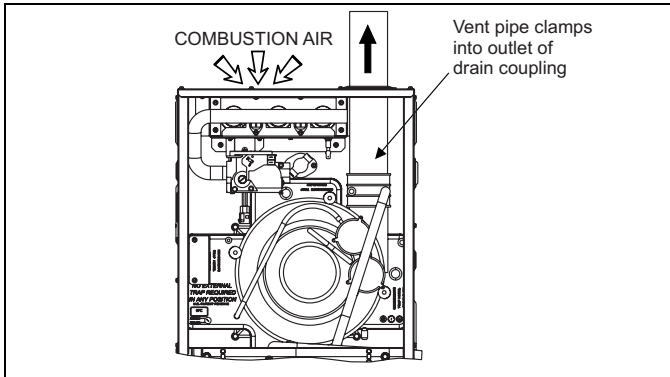

FIGURE 42: Combustion Airflow Path Through The Furnace Casing

1. The free area of a supply air opening shall be calculated by subtracting the blockage area of all fixed louvers grilles or screens from the gross area of the opening.
2. Apertures in a fixed louver, a grille, or screen shall have no dimension smaller than 1/4" (6.4 mm).
3. A manually operated damper or manually adjustable louvers are not permitted for use.
4. A automatically operated damper or automatically adjustable louvers shall be interlocked so that the main burner cannot operate unless either the damper or the louver is in the fully open position.

WARNING

This type of installation requires that the supply air to the appliance(s) be of a sufficient amount to support all of the appliance(s) in the area. Operation of a mechanical exhaust, such as an exhaust fan, kitchen ventilation system, clothes dryer or fireplace may create conditions requiring special attention to avoid unsatisfactory operation of gas appliances. A venting problem or a lack of supply air will result in a hazardous condition, which can cause the appliance to soot and generate dangerous levels of CARBON MONOXIDE, which can lead to serious injury, property damage and / or death.

WARNING

*When a Category I furnace is removed or replaced, the original venting system may no longer be correctly sized to properly vent the attached appliances.
An improperly sized vent system can cause CARBON MONOXIDE to spill into the living space causing personal injury, and or death.*

An **unconfined space** is not less than 50 ft³ (1.42 m³) per 1,000 BTU/hr (0.2928 kW) input rating for all of the appliances installed in that area.

Rooms communicating directly with the space containing the appliances are considered part of the unconfined space, if doors are furnished with openings or louvers.

A **confined space** is an area with less than 50 ft³ (1.42 m³) per 1,000 BTU/hr (0.2928 kW) input rating for all of the appliances installed in that area. The following must be considered to obtain proper air for combustion and ventilation in confined spaces.

Dampers, Louvers and Grilles

The blocking effects of louvers, grilles and screens must be given consideration in calculating free area. If the free area of a specific louver or grille is not known, refer to Table 11 to estimate free area.

Table 11: Estimated Free Area

Wood or Metal Louvers or Grilles	Wood 20-25%* Metal 60-70% *
Screens+	1/4" (6.4 mm) mesh or larger 100%

* Do not use less than 1/4" (6.4 mm) mesh.
+ Free area of louvers and grille varies widely; the installer should follow louver or grille manufacturer's instructions.

Table 12: Unconfined Space Minimum Area

BTUH Input Rating	Minimum Free Area Required for Each Opening
60,000	60 in ² (387 cm ²)
80,000	80 in ² (516 cm ²)
100,000	100 in ² (645 cm ²)
120,000	120 in ² (742 cm ²)

Table 13: Free Area

BTUH Input Rating	Minimum Free Area Required for Each Opening		
	Horizontal Duct (2,000 BTUH)	Vertical Duct or Opening to Outside (4,000 BTUH)	Round Duct (4,000 BTUH)
60,000	30 in ² (193 cm ²)	15 in ² (97 cm ²)	5" (13 cm)
80,000	40 in ² (258 cm ²)	20 in ² (129 cm ²)	5" (13 cm)
100,000	50 in ² (322 cm ²)	25 in ² (161 cm ²)	6" (15 cm)
120,000	60 in ² (387 cm ²)	30 in ² (193 cm ²)	7" (18 cm)

EXAMPLE: Determining Free Area.

Appliance	1 Appliance	2 Total Input
100,000	+ 30,000 = (130,000 ÷ 4,000) = 32.5 Sq. In. Vertical	
Appliance	1 Appliance	2 Total Input
100,000	+ 30,000 = (130,000 ÷ 2,000) = 65 Sq. In. Horizontal	

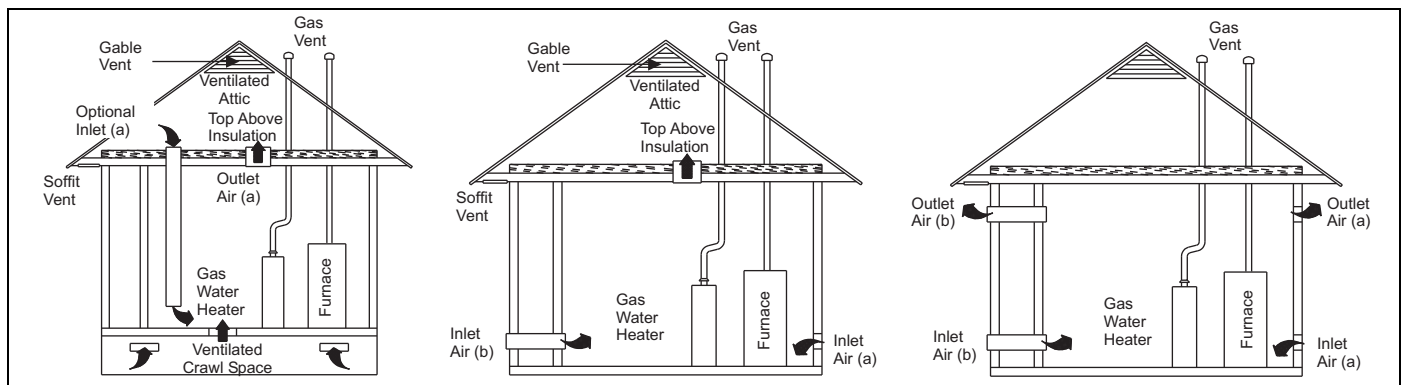

FIGURE 43: Ambient Combustion Air

Air Supply Openings and Ducts

1. An opening may be used in lieu of a duct to provide to provide the outside air supply to an appliance unless otherwise permitted by the authority having jurisdiction. The opening shall be located within 12" (30.5 cm) horizontally from, the burner level of the appliance. Refer to "AIR SOURCE FROM OUTDOORS AND VENT AND SUPPLY AIR SAFETY CHECK" in these instructions for additional information and safety check procedure.
2. The duct shall be either metal, or a material meeting the class 1 requirements of CAN4-S110 Standard for Air Ducts.
3. The duct shall be least the same cross-sectional area as the free area of the air supply inlet opening to which it connects.
4. The duct shall terminate within 12" (30.5 cm) above, and within 24" (61 cm) horizontally from, the burner level of the appliance having the largest input.
5. A square or rectangular shaped duct shall only be used when the required free area of the supply opening is 9 in² (58.06 cm²) or larger. When a square or rectangular duct is used, its small dimension shall not be less than 3" (7.6 cm).
6. An air inlet supply from outdoors shall be equipped with a means to prevent the direct entry of rain and wind. Such means shall not reduce the required free area of the air supply opening.
7. An air supply inlet opening from the outdoors shall be located not less than 12" (30.5 cm) above the outside grade level.

Combustion Air Source from Outdoors

1. Two permanent openings, one within 12" (30.5 cm) of the top and one within 12" (30.5 cm) of bottom of the confined space, Two permanent openings, shall communicate directly or by means of ducts with the outdoors, crawl spaces or attic spaces.
2. One permanent openings, commencing within 12" (30.5 cm) of the top of the enclosure shall be permitted where the equipment has clearances of at least 1" (2.54 cm) from the sides and back and 6" (15.2 cm) from the front of the appliance. The opening shall communicate directly with the outdoors and shall have a minimum free area of:

- a. 1 square in. per 3000 BTU per hour (6.45 cm³ per 0.879 kW) of the total input rating of all equipment located in the enclosure.
 - b. Not less than the sum of all vent connectors in the confined space.
3. The duct shall be least the same cross-sectional area as the free area of the air supply inlet opening to which it connects.
 4. The blocking effects of louvers, grilles and screens must be given consideration in calculating free area. If the free area of a specific louver or grille is not known, refer to Table 11.

Ventilated Combustion Air

The ventilated attic space or a crawl space from which the combustion air is taken must comply with the requirements specified in "AIR SOURCE FROM OUTDOORS" in this instruction or in Section 5.3, Air for Combustion and Ventilation of the National Fuel Gas Code, ANSI Z223.1 (latest edition). This type installation requires two properly sized pipes. One brings combustion air from a properly ventilated attic space or crawl space and a second pipe that extends from the furnace vent connection (top right of unit) to the exterior of the building. Refer to Table 7 for intake pipe sizing, allowable length and elbow usage. Follow all notes, procedures and required materials in the "COMBUSTION AIR/VENT PIPE SIZING" section in these instructions when installing the combustion air pipe from the unit and into a ventilated attic space or crawl space. DO NOT terminate vent pipe in an Attic or Crawl Space.

Ventilated Combustion Air Termination

Refer to Figure 44 for required attic termination for the combustion air intake pipe. For attic termination, use two 90° elbows with the open end in a downward position. Be sure to maintain 12" (30.5 cm) clearance above any insulation, flooring or other material.

A crawl space combustion air installation consists of a straight pipe from the PVC coupling on the burner box that extends into the crawl space and terminates with a 1/4" (6.4 mm) mesh screen and no elbows.

▲ WARNING

CARBON MONOXIDE POISONING HAZARD

Failure to follow the steps outlined below for each appliance connected to the venting system being placed into operation could result in carbon-monoxide poisoning or death.

The following steps shall be followed for each appliance connected to the venting system being placed into operation, while all other appliances connected to the venting system are not in operation:

1. Inspect the venting system for proper size and horizontal pitch. Determine that there is no blockage, restriction, leakage, corrosion or other deficiencies, which could cause an unsafe condition
2. Close all building doors and windows and all doors.
3. Turn on clothes dryers and TURN ON any exhaust fans, such as range hoods and bathroom exhausts, so they shall operate at maximum speed. Open the fireplace dampers. Do not operate a summer exhaust fan.
4. Follow the lighting instructions. Place the appliance being inspected in operation. Adjust thermostat so the appliance shall operate continuously.
5. Test each appliance (such as a water heater) equipped with a draft hood for spillage (down-draft or no draft) at the draft hood relief opening after 5 minutes of main burner operation. Appliances that do not have draft hoods need to be checked at the vent pipe as close to the appliance as possible. Use a combustion analyzer to check the CO₂ and CO levels of each appliance. Use a draft gauge to check for a downdraft or inadequate draft condition.
6. After it has been determined that each appliance properly vents when tested as outlined above, return doors, windows, exhaust fans, fireplace dampers and any other gas burning appliance to their normal condition.
7. If improper venting is observed during any of the above tests, a problem exists with either the venting system or the appliance does not have enough combustion air (Supply Air from outside) to complete combustion. This condition must be corrected before the appliance can function safely.

NOTE: An unsafe condition exists when the CO reading exceeds 40 ppm and the draft reading is not in excess of - 0.1" w.c. (-25 kPa) with all of the appliance(s) operating at the same time.

8. Any corrections to the venting system and / or to the supply (outside) air system must be in accordance with the National Fuel Gas Code Z223.1 or CAN/CGA B149.1 Natural Gas and Propane Installation Code (latest editions). If the vent system must be resized, follow the appropriate tables in Appendix G of the above codes or for this appliance.

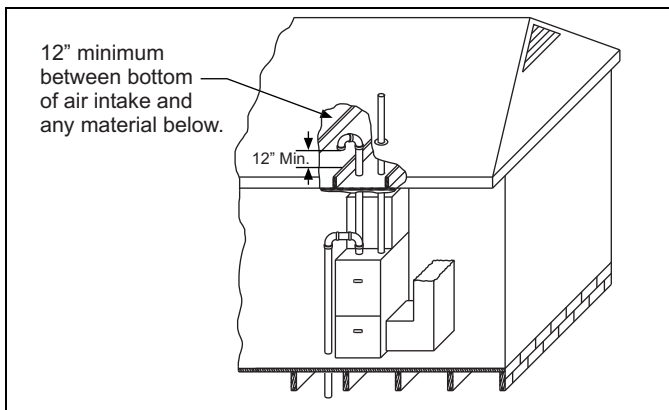

FIGURE 44: Attic and Crawl Space Combustion Air Termination

Specially Engineered Installations

The above requirements shall be permitted to be waived where special engineering, approved by the authority having jurisdiction, provides an adequate supply of air for combustion and ventilation.

WARNING

Be sure to instruct the owner not to block this intake pipe.

VENT BLOWER ROTATION

For ease of venting, the vent blower may be rotated 90° in either direction. For upflow installations the vent may exit through the top or either side of the cabinet. For downflow installations, the vent blower must be rotated so that the vent exits through either side of the cabinet. See Figures 29-32 for illustrations of different inducer rotation positions.

SECTION VIII: START-UP AND ADJUSTMENTS

The initial start-up of the furnace requires the following additional procedures:

IMPORTANT

All electrical connections made in the field and in the factory should be checked for proper tightness.

When the gas supply is initially connected to the furnace, the gas piping may be full of air. In order to purge this air, it is recommended that the ground union be loosened until the odor of gas is detected. When gas is detected, immediately retighten the union and check for leaks. Allow five minutes for any gas to dissipate before continuing with the start-up procedure. Be sure proper ventilation is available to dilute and carry away any vented gas.

GAS PIPING LEAK CHECK

WARNING

FIRE OR EXPLOSION HAZARD

Failure to follow the safety warnings exactly could result in serious injury, death or property damage.

Never test for gas leaks with an open flame. Use a commercially available soap solution made specifically for the detection of leaks to check all connections. A fire or explosion may result causing property damage, personal injury or loss of life.

IMPORTANT

Burner ignition may not be satisfactory on first startup due to residual air in the gas line or until gas manifold pressure is adjusted. The ignition control will make three attempts to light before locking out.

It is recommended that when the gas supply is first connected to the furnace, the ground union be loosened until the odor of gas is detected. When gas is detected, immediately tighten the union and check for gas leaks. Allow five minutes for any gas to dissipate before continuing with the startup procedure. Be sure that proper ventilation is available to dilute and carry away any vented gas.

With furnace in operation, check all of the pipe joints, gas valve connections and manual valve connections for leakage using an approved gas detector, a non-corrosive leak detection fluid or other leak detection methods. Take appropriate action to stop any leak. If a leak persists, replace the faulty component.

The furnace and its equipment shutoff valve must be disconnected from the gas supply during any pressure testing of that system at test pressures in excess of 0.5 psig (3.45 kPa).

The furnace must be isolated from the gas supply piping system by closing the equipment shutoff valve during any pressure testing of the gas supply system.

WARNING

HOT SURFACE IGNITION SYSTEM

Do not attempt to light this furnace by hand (with a match or any other means). There may be a potential shock hazard from the components of the hot surface ignition system. The furnace can only be lit automatically by its hot surface ignition system.

SETUP TEST MODE

During normal operation, the furnace input rate can vary between 35% and 100% of full nameplate input, making it difficult to check for proper operation. To help with the furnace startup process, the control has a TEST MODE available that allows the furnace input rate to stay at a constant input rate. To access this TEST MODE perform the following sequence:

1. With power to the board on and with no thermostat calls (no call for heating, cooling or continuous fan), push and hold the TEST button on the board for one second. The LED on the board will glow red.
2. Release the TEST button. The LED on the board will flash a rapid green signal, indicating that TEST MODE is activated.
3. Turn the thermostat to call for heat (R & W signal).
4. The furnace will light and operate at high (100%) firing rate. The furnace firing rate should be checked at this level to confirm that the furnace is not overfired or underfired.
5. To run the furnace at minimum rate (35%), press the ERROR button once. The LED will flash one green flash to confirm.
6. To run the furnace at a middle rate (70%), press the ERROR button twice within a five-second period. The LED will flash green two times to confirm.
7. To again operate the furnace at maximum (100%) rate, press the ERROR button three times within a five-second period. The LED will flash green three times to confirm.
8. If the thermostat call for heat is removed, the LED will flash a rapid green signal, indicating that the furnace is still in TEST MODE.
9. When startup tests are completed, turning off power to the board will take the furnace out of TEST MODE and will restore normal operation. The furnace will automatically return to normal operation after 150 minutes if power is not cycled.

CALCULATING THE FURNACE INPUT (NAT. GAS)

Burner orifices are sized to provide proper input rate using natural gas with a heating value of 1030 BTU/Ft³ (38.4 MJ/m³). If the heating value of your gas is significantly different, it may be necessary to replace the orifices.

NOTICE

DO NOT set manifold pressure less than 3.2" w.c. or more than 3.8" w.c. for natural gas at sea level. If manifold pressure is outside this range, change main burner orifices.

NOTICE

If orifice hole appears damaged or it is suspected to have been redrilled, check orifice hole with a numbered drill bit of correct size. Never redrill an orifice. A burr-free and squarely aligned orifice hole is essential for proper flame characteristics.

CAUTION

DO NOT bottom out gas valve regulator adjusting screw. This can result in unregulated manifold pressure and result in excess over-fire and heat exchanger failures.

- Multiply cubic feet per hour by heating valve (BTU/ft³) to obtain input.

If clocked rate does not match the input rate from the unit nameplate, follow steps in next section to adjust the manifold pressure. Repeat steps 2 - 5 until correct input is achieved.

CAUTION

Be sure to relight any gas appliances that were turned off at the start of this input check.

HIGH ALTITUDE NATURAL GAS ORIFICE CONVERSION

The National Fuel Gas Code requires that gas appliances installed above 2,000 feet elevation have their inputs de-rated by 4% per 1,000 feet above sea level. The modulating furnaces automatically de-rate for altitude by measuring the inducer blower pressure and using that to determine if there is adequate air to support good combustion. If there is not enough combustion air to properly support 100% of the furnace nameplate input rate, the control will reduce the input to the point that there will be good combustion.

Verify natural gas input rate by clocking meter.

- Turn off all other gas appliances and pilots.
- Run furnace for a minimum of 3 minutes in heating operation.
- Measure time (in sec) for gas meter to complete 1 revolution and note reading. The 2 cubic feet dial provides a more accurate measurement of gas flow.
- Refer to Table 14 for cubic feet of gas per hour.

Table 14: Gas Rate (CU FT/HR) at Full Input

Seconds For 1 Revolution	Size of Test Dial		
	1 Cu Ft	2 Cu Ft	5 Cu Ft
10	360	720	1800
11	327	655	1636
12	300	600	1500
13	277	555	1385
14	257	514	1286
15	240	480	1200
16	225	450	1125
17	212	424	1059
18	200	400	1000
19	189	379	947
20	180	360	900
21	171	343	857
22	164	327	818
23	157	313	783
24	150	300	750
25	144	288	720
26	138	277	692
27	133	267	667
28	129	257	643
29	124	248	621
30	120	240	600
31	116	232	581
32	113	225	563
33	109	218	545
34	106	212	529
35	103	206	514
36	100	200	500
37	97	195	486
38	95	189	474
39	92	185	462
40	90	180	450
41	88	176	439
42	86	172	429
43	84	167	419
44	82	164	409
45	80	160	400
46	78	157	391
47	76	153	383
48	75	150	375
49	73	147	367

Seconds For 1 Revolution	Size of Test Dial		
	1 Cu Ft	2 Cu Ft	5 Cu Ft
50	72	144	360
51	71	141	355
52	69	138	346
53	68	136	340
54	67	133	333
55	65	131	327
56	64	129	321
57	63	126	316
58	62	124	310
59	61	122	305
60	60	120	300
62	58	116	290
64	56	112	281
66	54	109	273
68	53	106	265
70	51	103	257
72	50	100	250
74	48	97	243
76	47	95	237
78	46	92	231
80	45	90	225
82	44	88	220
84	43	86	214
86	42	84	209
88	41	82	205
90	40	80	200
92	39	78	196
94	38	76	192
96	38	75	188
98	37	74	184
100	36	72	180
102	35	71	178
104	35	69	173
106	34	68	170
108	33	67	167
110	33	65	164
112	32	64	161
116	31	62	155
120	30	60	150

ADJUSTMENT OF MANIFOLD GAS PRESSURE

Inlet and manifold gas pressure may be measured by connecting the "U" tube manometer to the gas valve with a piece of tubing. Follow the appropriate section in the instructions below. Refer to Figure 45 for the locations of the pressure ports on the gas valve.

Table 15: Inlet Gas Pressure Range

INLET GAS PRESSURE RANGE		
	Natural Gas	Propane (LP)
Minimum*	4.5" w.c. (1.12 kPa)	8.0" w.c. (1.99 kPa)
Maximum	10.5" w.c. (2.61 kPa)	13.0" w.c. (3.24 kPa)

IMPORTANT

The inlet gas pressure operating range table specifies what the minimum and maximum gas line pressures must be for the furnace to operate safely. The gas line pressure **MUST BE** a minimum of:

- 7" w.c. (1.74 kPa) for Natural Gas
- 11" w.c. (2.74 kPa) for Propane (LP) Gas

in order to obtain the BTU input specified on the rating plate and/or the nominal manifold pressure specified in these instructions and on the rating plate.

NOTICE

The regulated outlet pressure has been calibrated at the factory. Additional pressure adjustment should not be necessary. If adjustment is necessary, set to the following specifications. After adjustment, check for gas leakage.

TABLE 16: Nominal Manifold Pressure

NOMINAL MANIFOLD PRESSURE	
Natural Gas (Max)	3.5" w.c. (0.87 kPa)
Natural Gas (Min)	0.5" w.c. (0.15 kPa)
Propane (LP) Gas (Max)	10.0" w.c. (2.49 kPa)
Propane (LP) Gas (Min)	1.6" w.c. (0.40 kPa)

Turn gas off at the ball valve or gas cock on gas supply line before the gas valve. Find the pressure ports on the gas valve marked OUT P and IN P.

1. The manifold pressure must be taken at the port marked OUT P.
2. The inlet gas line pressure must be taken at the port marked IN P.
3. Using a 3/16" allen wrench, remove the plugs from the inlet and outlet pressure ports. Connect a 1/8" UPT barbed hose fitting to each pressure port.
4. Refer to Figure 45 for location of pressure regulator adjustment screw on main gas valve.
5. Turn gas and electrical supplies on and follow the operating instructions to place the unit back in operation.
6. Use a small slotted screwdriver to turn the regulator adjustment screw. Adjust the pressure by turning the screw one click at a time until desired pressure is reached. Wait a few seconds after each adjustment to allow the pressure to stabilize before making additional adjustments. This is an electronic adjustment screw that does not require very much force. Application of excessive force to the adjustment screw will damage the gas valve.

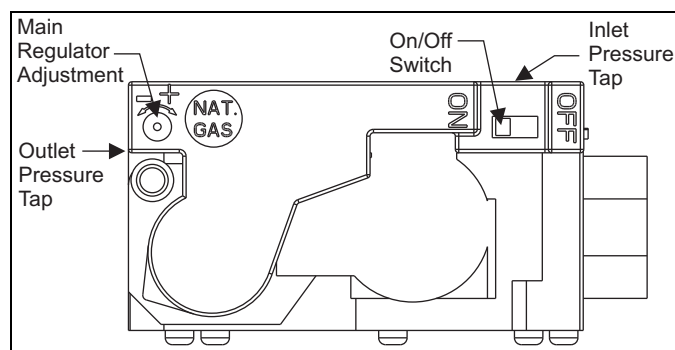

FIGURE 45: Gas Valve

IMPORTANT

If gas valve regulator is turned clockwise, manifold pressure is increased. If screw is turned counterclockwise, manifold pressure will decrease.

The adjustment screw has a range of 16 clicks (about ± 0.5 " manifold pressure). There is not a hard stop at the ends of the adjustment range. When the limit of the adjustment range is reached, the next click will start over at the other end of the range. For instance, if you are increasing pressure and reach the upper limit of adjustment the next click will drop the pressure to the lower limit.

7. After the manifold pressure has been adjusted, re-calculate the furnace input to make sure you have not exceeded the specified input on the rating plate. Refer to "CALCULATING THE FURNACE INPUT (NAT. GAS)".
8. Once the correct BTU (kW) input has been established, turn the gas valve to OFF and turn the electrical supply switch to OFF; then remove the flexible tubing and fittings from the gas valve pressure tap replace the pressure tap plugs.
9. Turn the electrical and gas supplies back on, and with the burners in operation, check for gas leakage around the gas valve pressure port for leakage using an approved gas detector, a non-corrosive leak detection fluid, or other leak detection methods.

ADJUSTMENT OF TEMPERATURE RISE

DANGER

The temperature rise, or temperature difference between the return air and the supply (heated) air from the furnace, must be within the range shown on the furnace rating plate and within the application limitations shown in Table 6.

The supply air temperature cannot exceed the "Maximum Supply Air Temperature" specified in these instructions and on the furnace rating plate. Under NO circumstances can the furnace be allowed to operate above the Maximum Supply Air Temperature. Operating the furnace above the Maximum Supply Air Temperature will cause premature heat exchanger failure, high levels of Carbon Monoxide, a fire hazard, personal injury, property damage, and/or death.

After about 5 minutes of operation, determine the furnace temperature rise. Take temperature readings of both the return air and the heated air in the ducts about six feet away from the furnace, where they will not be affected by radiant heat. Increase or decrease the temperature rise by changing the ATR jumper on the furnace control board. The jumper is factory-set to deliver an air temperature rise near the midpoint of the nameplate temperature rise range. If more air is desired (lower temperature rise), move the jumper to the -10 position. If less air is desired (higher temperature rise), move the jumper to the +10 position.

ADJUSTMENT OF FAN CONTROL SETTINGS

Cooling - The airflow delivered by the furnace during cooling operation can be adjusted to match the cooling capacity of the A/C condensing unit. This is done by moving the COOL and ADJ jumper on the control board to give the desired airflow.

The COOL jumper has four positions, which will deliver the airflow in cooling mode shown in Table 17.

The ADJ jumper has three positions which can be used to make further adjustments to the cooling blower airflow.

Continuous Fan Operation - The airflow delivered by the furnace during continuous fan operation can be adjusted as desired. This is done by moving the control fan jumper on the control board to give the desired airflow.

The jumper has three positions. The "H" position delivers maximum airflow, 100% of the blower capacity. Position "M" delivers approximately 70% of the blower capacity. And Position "L" delivers minimum airflow, approximately 40% of the blower capacity.

Delay Taps Selection

The set of jumper pins on the control board labeled "DELAY" are used to set the delay profiles for the furnace. These can be chosen so as to maximize the comfort and sound levels for various regions of the country.

Tap A is the default profile. It provides a 30-second ramp-up from zero airflow to full capacity and a 30-second ramp-down from full capacity back to zero airflow. Whenever there is a change in airflow mode, such as from low heat to high heat, the motor will take 30 seconds to ramp from one speed to the other.

Tap B is the humid profile. This profile is best-suited for installations where the humidity is frequently very high during cooling season, such as in the southern part of the country. On a call for cooling, the blower will ramp up to 50% of full capacity and will stay there for two minutes, then will ramp up to 82% of full capacity and will stay there for five minutes, and then will ramp up to full capacity, where it will stay until the wall thermostat is satisfied. In every case, it will take the motor 30 seconds to ramp from one speed to another.

Tap C is the dry profile. This profile is best suited to parts of the country where excessive humidity is not generally a problem, where the summer months are usually dry. On a call for cooling the motor will ramp up to full capacity and will stay there until the thermostat is satisfied. At the end of the cooling cycle, the blower will ramp down to 50% of full capacity where it will stay for 60 seconds. Then it will ramp down to zero. In every case, it will take the motor 30 seconds to ramp from one speed to another.

Tap D is the normal profile, best suited for most of the country, where neither excessive humidity nor extremely dry conditions are the norm. On a call for cooling, the motor will ramp up to 63% of full capacity and will stay there for 90 seconds, then will ramp up to full capacity. At the end of the cooling cycle, the motor will ramp down to 63% of full capacity and will stay there for 30 seconds, then will ramp down to zero. In every case, it will take the motor 30 seconds to ramp from one speed to another.

Humidistat

When a humidistat is installed in the system, the "Humidistat connected?" jumper on the control board should be moved to the "YES" position. The cooling airflow will then be reduced by 15% whenever the humidistat indicates high humidity.

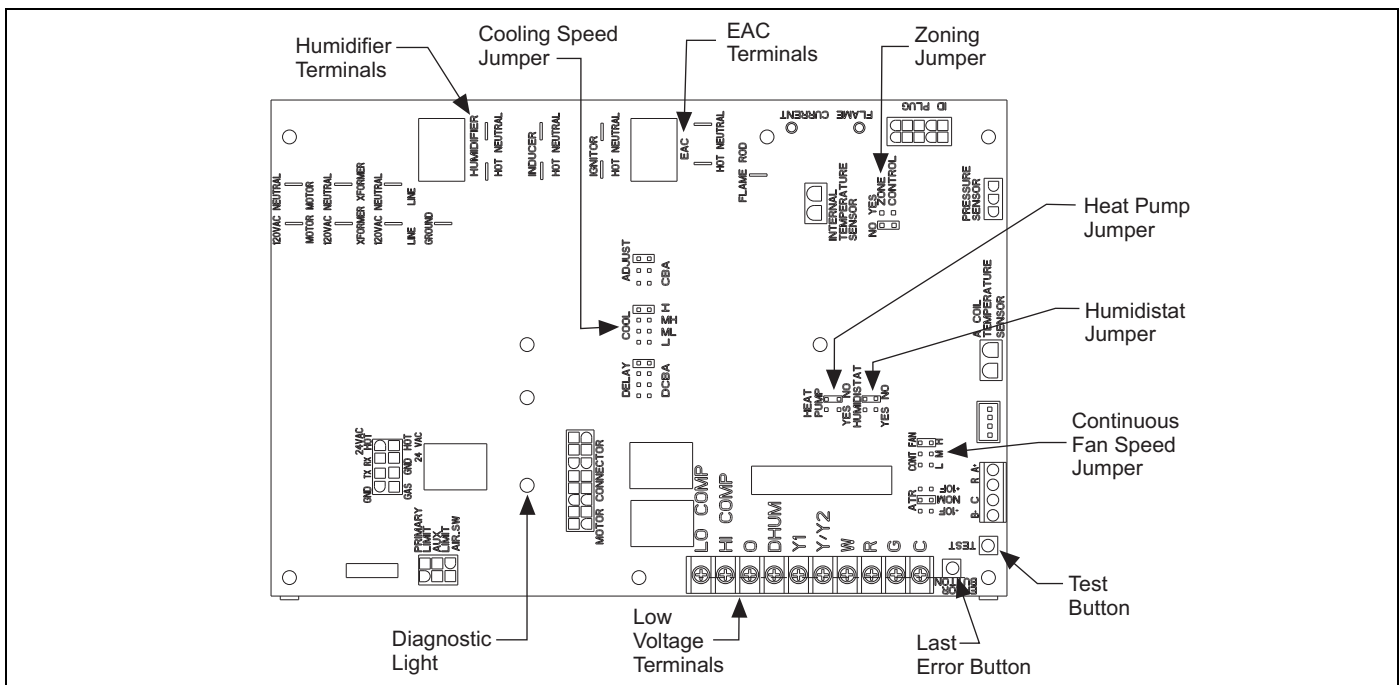

FIGURE 46: Furnace Control Board

Table 17: Blower Performance CFM - Any Position

High / Low Speed Cooling CFM					
060B12		080B12		Jumper Settings	
Hi Cool	Lo Cool	Hi Cool	Lo Cool	COOL Jumper	ADJ Jumper
1305	850	1290	840	H	B
1100	715	1090	710	MH	B
1065	690	1015	660	H	A
1000	650	1000	650	MH	A
960	625	960	625	H	C
760	495	760	495	ML	B
900	585	900	585	MH	C
660	430	660	430	L	B
690	450	680	445	ML	A
600	400	600	400	L	A
620	400	620	400	ML	C
550	400	540	400	L	C
High / Low Speed Cooling CFM					
080C16		100C16		Jumper Settings	
Hi Cool	Lo Cool	Hi Cool	Lo Cool	COOL Jumper	ADJ Jumper
1670	1085	1655	1075	H	B
1295	840	1275	820	MH	B
1385	900	1345	875	H	A
1175	765	1160	755	MH	A
1245	810	1210	785	H	C
995	645	1000	650	ML	B
1055	685	1045	680	MH	C
935	605	955	620	L	B
905	590	910	590	ML	A
850	550	870	565	L	A
815	530	815	530	ML	C
765	500	785	510	L	C
High / Low Speed Cooling CFM					
100C20		120D20		Jumper Settings	
Hi Cool	Lo Cool	Hi Cool	Lo Cool	COOL Jumper	ADJ Jumper
2215	1440	2180	1415	H	B
1765	1145	1760	1140	MH	B
1820	1180	1800	1170	H	A
1605	1040	1595	1035	MH	A
1635	1060	1620	1050	H	C
1270	825	1255	815	ML	B
1445	940	1435	935	MH	C
1055	685	1050	680	L	B
1155	750	1160	755	ML	A
960	620	960	615	L	A
1040	675	1035	670	ML	C
860	560	840	545	L	C

NOTE:

All CFM's are shown at 0.5" w.c. external static pressure. These units have variable speed motors that automatically adjust to provide constant CFM from 0.0" to 0.6" w.c. static pressure. From 0.6" to 1.0" static pressure, CFM is reduced by 2% per 0.1" increase in static. Operation on duct systems with greater than 1.0" w.c. external static pressure is not recommended.

At some settings, LOW COOL airflow may be lower than what is required to operate an airflow switch on certain models of electronic air cleaners. Consult the instructions for the electronic air cleaner for further details.

SECTION IX: SAFETY CONTROLS

CONTROL CIRCUIT FUSE

A 3-amp fuse is provided on the control circuit board to protect the 24-volt transformer from overload caused by control circuit wiring errors. This is an ATO 3, automotive type fuse and is located on the control board.

BLOWER DOOR SAFETY SWITCH

This unit is equipped with an electrical interlock switch mounted in the burner compartment. This switch interrupts all power at the unit when the panel covering the blower compartment is removed.

Electrical supply to this unit is dependent upon the panel that covers the blower compartment being in place and properly positioned.

CAUTION

Main power to the unit must still be interrupted at the main power disconnect switch before any service or repair work is to be done to the unit. Do not rely upon the interlock switch as a main power disconnect. Blower and burner must never be operated without the blower panel in place.

ROLLOUT SWITCH CONTROLS

These controls are mounted on the burner assembly. If the temperature in the area surrounding burner exceeds its set point, the gas valve is de-energized. The operation of this control indicates a malfunction in the combustion air blower, heat exchanger or a blocked vent pipe connection. Corrective action is required. These are manual reset controls that must be reset before operation can continue.

PRESSURE CONTROLS

Pressure Sensor (Transducer) - This furnace is equipped with a pressure sensor in the burner compartment near the combustion blower. This sensor monitors combustion airflow through furnace and piping systems. If any of the conditions listed below are detected by the pressure sensor, the control board will prevent a hazardous condition from occurring by speeding up the combustion blower motor in order to maintain adequate combustion airflow. If the combustion blower is already turning at full speed, the furnace control will then start reducing the input to the furnace in order to maintain proper combustion with the amount of combustion airflow available. If there is not enough combustion air available to give proper combustion even at the minimum input rate (35%), the control will close the gas valve and shut off the burners. The sensor will detect the following conditions.

1. Blockage of vent piping or vent terminal
2. Failure of combustion air blower motor or blower wheel.
3. Blockage of combustion air piping or terminals.

Pressure Switch - This furnace is equipped with a pressure switch mounted on the draft inducer. This switch monitors the flow through the vent system. The switch will close at the beginning of each cycle when adequate combustion airflow is established. However, this switch may be open under certain conditions when the burners are lit. **The pressure sensor is the primary flow sensor.**

Condensate Pressure Switch - This furnace is equipped with a pressure switch that will shut the furnace burners off if the condensate drain line is blocked so that the water does not drain properly from the furnace.

LIMIT CONTROLS

Limit Switch - This furnace is equipped with a high temperature limit control mounted to the left side of the furnace vestibule panel. This limit switch will open and shut off gas to the burners if it detects excessive air temperature in the furnace, which can be caused by any of the following conditions:

1. Dirty filter
2. Failure of the circulating blower motor or wheel
3. Too many supply or return registers closed or blocked.

Temperature Sensor - This furnace is also equipped with a temperature sensor mounted to the vestibule panel, near the limit switch. This sensor monitors the temperature of the air being supplied to the home. If the sensor detects air temperature higher than normal, the furnace control will speed up the circulating blower motor in order to try to increase the amount of airflow being delivered, thereby reducing the air temperature.

SECTION X: NORMAL OPERATION AND DIAGNOSTICS

NORMAL OPERATION SEQUENCE

The furnace control calculates the optimum firing rate each time the wall thermostat R and W contacts close or open (at the beginning and at the end of each call for heat) based on information from the thermostat and past demand. **UNLIKE CONVENTIONAL SYSTEMS, THE WALL THERMOSTAT DOES NOT SIMPLY TURN THE FURNACE ON AND OFF. THE FURNACE CONTROL CALCULATES THE DEMAND AND MAY CONTINUE TO FIRE THE FURNACE DURING PORTIONS OF THE THERMOSTAT "OFF" CYCLE.**

When the wall thermostat R and W contacts close, indicating a call for heat, the following sequence occurs:

1. The inducer is energized and ramps up its speed until airflow is proven by the pressure switch and by the pressure sensor on the control board.
2. The hot surface ignitor is energized.
3. After a 17-20 second igniter heat-up, the gas valve opens and the burners light.
4. When the control senses that flame is present, the circulating blower starts at low speed.
5. The furnace fires at 70% of full rate for 30-45 seconds, then drops to the minimum (35%) firing rate.
6. The firing rate is automatically adjusted to meet demand, increasing gradually to maximum (100%) firing rate if the thermostat is not satisfied within a defined time.
7. When the thermostat R and W contacts open (thermostat is satisfied) the furnace control recalculates the demand and a new firing rate.
 - a. If demand exceeds the minimum firing rate, the burners will continue to fire at a recalculated reduced firing rate, decreasing if the thermostat remains off for a defined time.
 - b. If demand does not exceed the minimum firing rate, the burners will shut off immediately.
8. After the burners shut off, the circulating blower will continue to run until the temperature sensor detects that the supply air temperature has dropped to the desired level, which should take from 30 to 90 seconds.

TROUBLESHOOTING

The following visual checks should be made before troubleshooting:

1. Check to see that the power to the furnace and the ignition control module is ON.
2. The manual shut-off valves in the gas line to the furnace must be open.
3. Make sure all wiring connections are secure.
4. Review the sequence of operation. Start the system by setting the thermostat above the room temperature. Observe the system's response. Then use the troubleshooting section in this manual to check the system's operation.

WARNING

Never bypass any safety control to allow furnace operation. Do so will allow furnace to operate under potentially hazardous conditions.

Do not try to repair controls. Replace defective controls with UPG Source 1 Parts.

Never adjust pressure switch to allow furnace operation.

FURNACE CONTROL DIAGNOSTICS

This furnace has built-in self-diagnostic capability. If a system problem occurs, a flashing LED shows a fault code. The LED can flash red, green or amber to indicate various conditions. The LED is located on the furnace control board and can be seen through the clear view port in the lower door of the furnace. To indicate an error condition, the LED will turn on for 1/4 second and off for 1/4 second. The pattern will be repeated the number of times equal to the flash code. For instance, a "six flash code" will be indicated by the LED turning on and off six times. There will be a two second off period between each set of flashes. The flash codes and an indication of their likely causes are listed below:

STEADY OFF - No 24V power to board. Check the 24 volt control circuit fuse on the board. Check the circuit breaker or fuse on the 115 volt supply power to the furnace. Check that the 24 volt transformer.

One Green Flash - Normal Operation with no call for heat.

Two Green Flashes - Indicator for "No error codes in memory". See Diagnostic Fault Code Storage and Retrieval section below.

Three Green Flashes - Indicator for "Error codes cleared from memory". See Diagnostic Fault Code Storage and Retrieval section below.

Rapid Green Flash - Control is in "Factory Speed-up" mode. This mode is used only during factory run-testing of the furnace. To stop this mode, cycle power to the furnace off and then back on.

One Amber Flash - Normal operation with call for cooling.

Two Amber Flashes - Normal operation with call for heat.

Three Amber flashes - Normal operation, burner is on at end of heating cycle after wall thermostat has been satisfied.

Four Amber Flashes - Heating capacity is reduced due to restriction in the circulating air system. Check for dirty filter or closed registers.

Five Amber Flashes - Heating capacity is reduced due to restriction in the combustion air or vent system. Check for blocked vent/air pipe or clogged condensate drain. Above 4,000 feet altitude, this may also indicate automatic, normal derating for altitude. See page 7 for additional high altitude information.

Six Amber Flashes - (Heat Pump applications only) Normal operation with call for heat pump heating.

Rapid Amber Flash - Low flame sense current. Check for dirty or mislocated flame sensor rod.

One Red Flash - Flame is present with no power being supplied to gas valve. This can be caused by a gas valve that is slow to close or that leaks gas through to the burners.

Two Red Flashes - Pressure switch closed with inducer pressure below pressure switch setpoint (switch is closed when it should be open). Check pressure switch and pressure transducer.

Three Red Flashes - Pressure switch open with inducer pressure above pressure switch setpoint (switch is open when it should be closed). Check pressure switch and pressure transducer.

Four Red Flashes - High limit switch open or defective temperature sensor or 24 volt fuse is open. This may be caused by a dirty air filter, improperly sized duct system, faulty blower motor, restricted circulating airflow an open fuse on the control board.

Five Red Flashes - Rollout switch or condensate pressure switch open. Check the rollout switch(es) on the burner assembly. It is a manual reset switch. To reset, push the small button in the center of the switch. If it cannot be reset or if the switch trips again, contact a qualified serviceman.

Six Red Flashes - Gas valve communication error.

Seven Red Flashes - Lockout due to no ignition. The control will try three times for ignition. If flame cannot be established in three tries, the control will lockout for one hour and then will try again to light. Check gas supply, ignitor, gas valve, flame sensor.

Eight Red Flashes - Lockout due to too many flame recycles. This flash code occurs if flame is lost five times during a single heating cycle. This could be caused by a faulty gas valve, low gas pressure, or dirty flame sensor. The control will lock out for one hour and then will try again.

Nine Red Flashes - Reversed line polarity or improper grounding. Check polarity of the incoming power to the furnace. Check the grounding of the furnace, including the transformer ground and the L1 and neutral connections.

Ten Red Flashes - Gas valve circuit shorted. Check gas valve wiring. If correct, replace gas valve.

Eleven Red Flashes - Main blower failure - This flash code occurs when the main limit opens and fails to reclose within five minutes, indicating that the blower motor or blower wheel has failed.

Twelve Red Flashes - ID plug is not present or not connected properly, check for loose plug or loose wires in plug.

Steady On Red - Control fault has been detected or there is 115 volts present without 24 volts. Check whether there is 24 volts and 115 volts being supplied to the board. If not, correct the voltage problem. If there is both 24 and 115 voltage to the board, replace the control board.

IGNITION CONTROL FLAME SENSE LEVELS

Normal flame sense current is approximately
3.7 microamps DC (μ a)
Low flame signal warning starts at 1.5 microamps.
Low flame signal control lockout point is
0.1 microamps DC (μ a)

DIAGNOSTIC FAULT CODE STORAGE AND RETRIEVAL

The control in this furnace is equipped with memory that will store up to five error codes to allow a service technician to diagnose problems more easily. This memory will be retained even if power to the furnace is lost. **Only a qualified service technician should use this feature.**

The control stores up to five separate error codes. If more than five error codes have occurred since the last reset, only the five most recent will be retained. The furnace control board has a button, labeled "**LAST ERROR**" that is used to retrieve error codes. This function will only work if there are no active thermostat signals. So any call for heating, cooling or continuous fan must be terminated before attempting to retrieve error codes.

To retrieve the error codes, push the **LAST ERROR** button. The **LED** on the control will then flash the error codes that are in memory, starting with the most recent. There will be a two-second pause between each flash code. After the error codes have all been displayed, the **LED** will resume the normal slow green flash after a five second pause. To repeat the series of error codes, push the button again.

If there are no error codes in memory, the **LED** will flash two green flashes. To clear the memory, push the **LAST ERROR** button and hold it for more than five seconds. The **LED** will flash three green flashes when the memory has been cleared, then will resume the normal slow green flash after a five-second pause.

SECTION XI: REPLACEMENT PARTS LIST

DESCRIPTION
MOTOR
MOTOR, DIRECT DRIVE BLOWER
BLOWER, COMBUSTION
ELECTRICAL
CAPACITOR, RUN
SWITCH, LIMIT
CONTROL, FURNACE
IGNITER
SENSOR, FLAME
SWITCH, PRESSURE
SWITCH, DOOR
TRANSFORMER
VALVE, GAS
CONTROL, TEMPERATURE
AIR MOVING
HOUSING, BLOWER
WHEEL, BLOWER
FABRICATED PARTS
RESTRICTOR, COMBUSTION BLOWER
BURNER, MAIN GAS
BRACKET, IGNITER
SHELF, BLOWER
RAIL, BLOWER (2 Req'd)
BRACKET, BLOWER TRACK (2 Req'd)
HEAT EXCHANGER ASS'Y

DESCRIPTION
FABRICATED PARTS - Continued
MANIFOLD, GAS
PAN, BOTTOM
PANEL, TOP
PANEL, DOOR (2 Req'd)
PANEL, BLOCKOFF
MISCELLANEOUS
ORIFICE, BURNER (Natural #45)
SIGHT GLASS, OVAL (2 Req'd)
GASKET, FOAM (Door) (1.5 ft req'd)
PAN, CONDENSATE
BRACKET, DOOR
HARNESS, WIRING
FERRULE (3 Req'd)
GROMMET (3 Req'd)
MOTOR MOUNT
TUBING, SILICON
HOSE, RAIN GUTTER
HOSE, CONDENSATE
PLUG, SEAL, 7/8"
PLUG, SEAL, 2-3/8"
PLUG, VENT PIPE
BAG, PARTS
KNOB, QUARTER TURN (4 Req'd)
DIAGRAM, WIRING

REPLACEMENT PART CONTACT INFORMATION

This is a generic parts list. To request a complete parts list, refer to the contact information below:

- Visit our website at www.source1parts.com for the following information:
 1. Search for a part or browse the catalog.
 2. Find a dealer or distributor.
 3. Customer Service contact information.
 - a. Click on the "Brand Links" button
 - b. Click on the "Customer Service" button
- You can contact us by mail. Just send a written request to:

**Johnson Controls Unitary Products
Consumer Relations
5005 York Drive
Norman, OK 73069**

SECTION XII: WIRING DIAGRAM

Wiring Diagram -97+% Modulating Condensing Furnace with ECM Motor

CAUTION
OPEN ALL DISCONNECTS BEFORE SERVICING THIS UNIT

PRECAUTION
OUVREZ LES DISJONCTEURS AVANT DE PROCEDER AVEC LE SERVICE

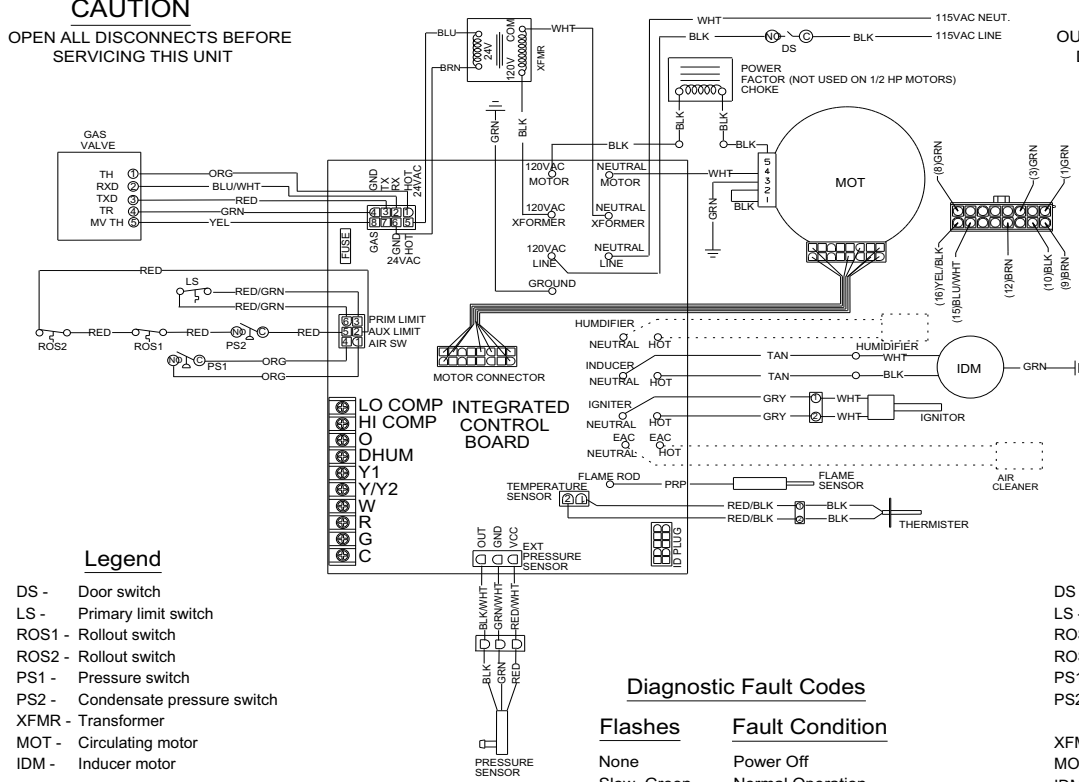

Diagnostic Fault Codes

Flashes	Fault Condition
None	Power Off
Slow Green	Normal Operation
Rapid Green	Factory speedup mode
Slow Amber	Normal Operation with call for cooling
Rapid Amber	Low flame sense current
2 Amber	Normal Operation with call for heat
3 Amber	Normal Operation, burner on at end of heat cycle
4 Amber	Reduced Airflow problem
5 Amber	High altitude installation OR vent, intake OR termination problem
6 Amber	Normal Operation with call for heat pump heating
Steady Red	Control Failure
1 Red	Flame present with gas off
2 Red	Check pressure switch wiring
3 Red	Vent, intake, or termination problem
4 Red	Airflow problem
5 Red	Flame Rollout OR open fuse
6 Red	Check gas valve wiring
7 Red	Failed to light burners
8 Red	Loss of flame during call for heat
9 Red	Hot/Neutral reversed OR poor ground/neutral
10 Red	Gas valve shorted "ON"
11 Red	Check blower motor/wiring
12 Red	ID plug missing OR not connected properly

ID Plugs

Model	Colors
60B12	BRN/YEL
80B12	RED/YEL
80C16	BLU/YEL
100C16	BLK/YEL
100C20	GRN/YEL
120D20	PUR/YEL

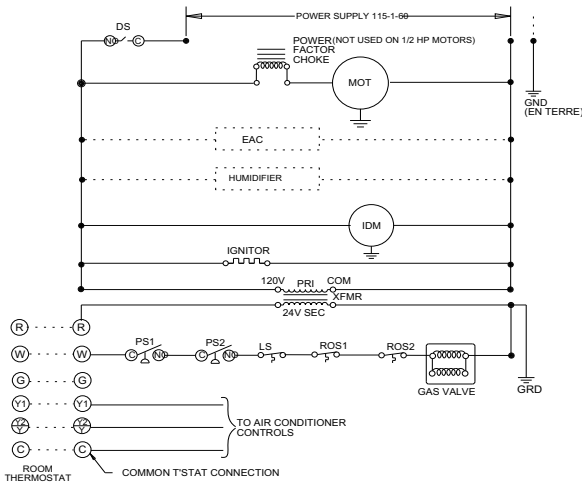

- NOTES:**
- If any of the original wire as supplied with the furnace must be replaced, it must be replaced with wiring material having a temperature rating of at least 221 degrees F (105 degrees C).
 - Connectors suitable for copper conductors only.

- NOTES:**
- Si l'un des fils d'origine fourni avec ce four doit être remplacé, il doit être remplacé avec le fil ayant un degré de température d'au moins 221 degrés F (105 degrés C).
 - Seulement des matettes pour fil de cuivre.

Fault Code Retrieval

Notice - Only a qualified service technician should use this feature.

Fault code retrieval functions will work only if there are no active thermostat signals.

To retrieve fault codes, push and release ERROR button on control board. The LED will flash the last five error codes, beginning with the most recent. If there are no fault codes in memory, the LED will give two green flashes. To clear the fault code memory, push and hold the ERROR button for at least five seconds. The LED will give three green flashes when the memory has been cleared.

Note to Servicers

Unlike conventional systems, the wall thermostat does not simply turn this furnace off and on. The furnace control calculates the demand and THE FURNACE BURNERS MAY CONTINUE TO FIRE DURING PART OF THE THERMOSTAT "OFF" CYCLE. Refer to the furnace instructions for further information.

1042428-UWD-A-0413

FIGURE 47: Wiring Diagram

NOTES

SECTION XIII: START UP SHEET

33" 97% - 98% AFUE Modulating Gas Furnace Start Up Sheet

Proper furnace start up is critical to customer comfort and equipment longevity

Start-Up Date

Technician Performing Start-Up

Installing Contractor Name

Owner Information

Name

Address

City

State or Province

Zip or Postal Code

Equipment Data

Furnace Model

Furnace Serial

Evaporator Coil Model

Evaporator Coil Serial

Outdoor Unit Model

Outdoor Unit Serial

Furnace Configuration
 Upflow Downflow Horizontal Left Horizontal Right
Filter, Thermostat, Accessories

Filter Type

Filter Size

Filter Location(s)

Thermostat Type

Other System Equipment and Accessories

Connections -- All Per Installation Instructions and Local Code
 Unit is level Gas piping is connected (including drip leg) Supply plenum and return air are connected
 Vent system is connected
Condensate Management
 Condensate tubing is correctly installed for the furnace position Condensate drain is connected
Venting

Intake Size

of 90 Degree Ells

Of 45 Degree Ells

Length

Exhaust Termination
 Roof
 Sidewall

Exhaust Size

of 90 Degree Ells

Of 45 Degree Ells

Length

Intake Termination
 Roof
 Sidewall
 Attic

 Venting system is the proper size, within the limitations of the chart in the installation instructions, properly connected to the furnace, and properly pitched
Electrical: Line Voltage
 Polarity is correct (black is L1 (hot), white is N (neutral)) Ground wire is connected

Line voltage value to furnace (volts AC)

Electrical: Low Voltage
 Thermostat heat anticipator set to .1 (if present)

 Thermostat wiring is complete Thermostat cycle rate set to 6 cycles/hour (if present)

Low voltage value between "R" and "C" on furnace control board (volts AC)

Continued on next Page

Gas Side

Gas Type Natural Gas LP Gas (Requires LP conversion kit)

LP Gas Conversion Kit Part # Used LP Conversion Kit Installed By

Inlet Gas Pressure (in. w.c.) Manifold Gas Pressure (in. w.c.) - furnace must be in TEST mode for setup

Calculated input in btuh - clock the gas meter (Nat Gas Only)

Burner flame inspected -- flames are blue and extending directly into the primary heat exchanger cells

Air Side: System External Static Pressure (Cooling Mode)

Supply static **before** evaporator coil (in w.c.) Supply static **after** evaporator coil (in w.c.)

Return Static (in w.c.) **before** filter Return Static (in w.c.) **after** filter (furnace side)

Total External Static Pressure

Air Side: Heating

ATR Setting NOM +10F -10F

Temperature Rise in Degrees F

Other Jumpers

De-humidistat YES NO

Heat Pump YES NO

Zone Control YES NO

Air Side: Cooling

COOL Speed Selected L (Low) ML (Med Low) MH (Med High) H (High)

ADJUST Setting (ECM Models) C B A

DELAY Setting (ECM Models) L (Low) ML (Med Low) MH (Med High) H (High)

Air Side: Continuous Fan

Blower Speed Selected L (Low) M (Med) H (High)

Cycle Test

Operate the furnace through several heating cycles from the thermostat, noting and correcting any problems

Operate the furnace through continuous fan cycles from the thermostat, noting and correcting any problems

Operate the furnace through cooling cycles (as applicable), noting and correcting any problems

Clean Up

Installation debris disposed of and furnace area cleaned up?

Owner Education

Give owner the owner's manual provided

Explain operation of system to equipment owner

Explain the importance of regular filter replacement and equipment maintenance

Explain thermostat use and programming (if applicable) to owner

Additional Job Detail